



Radar Systems Engineering

Lecture 17

Transmitters & Receivers

Dr. Robert M. O'Donnell
IEEE New Hampshire Section
Guest Lecturer



Block Diagram of Radar System

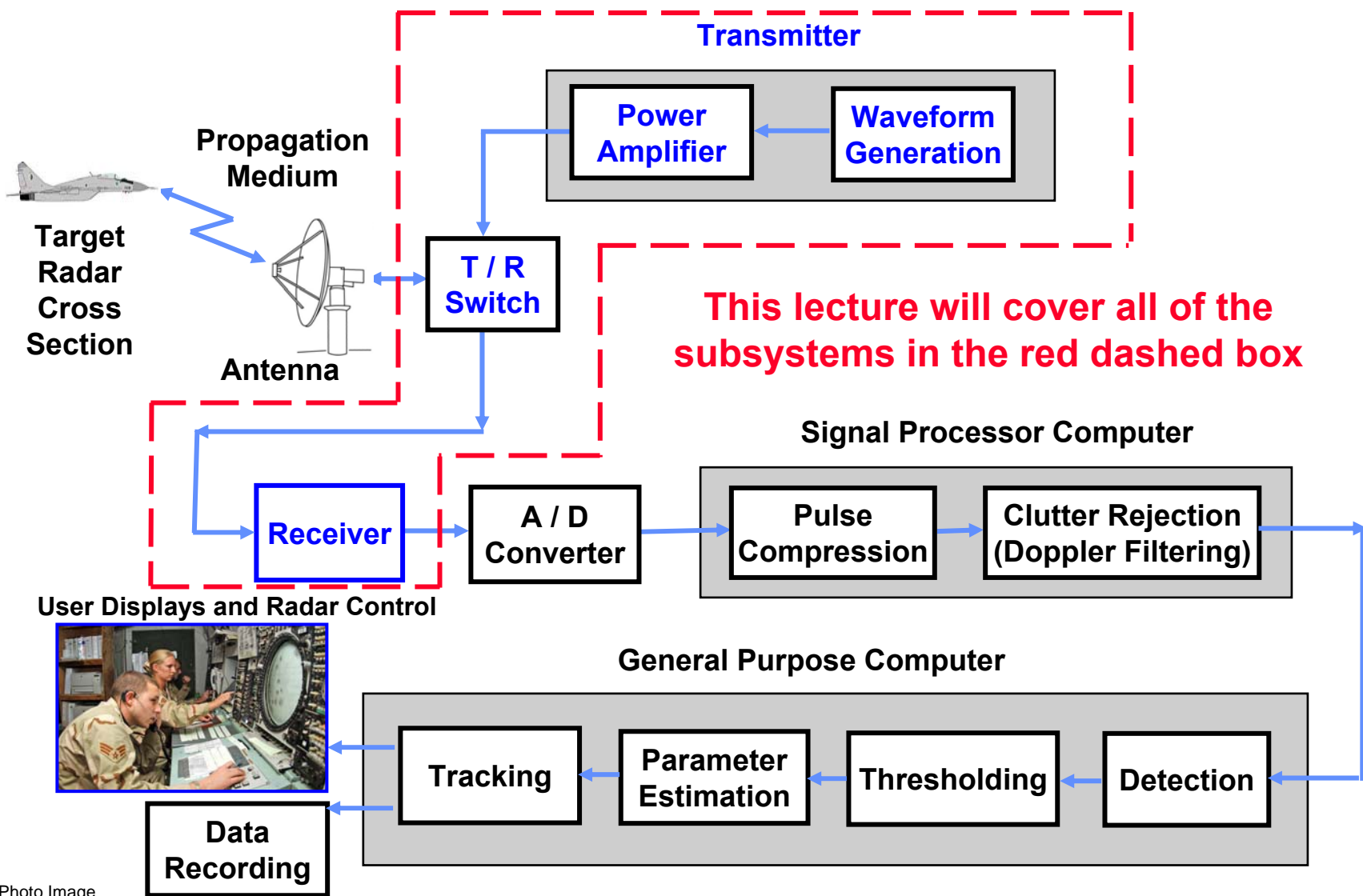

This lecture will cover all of the subsystems in the red dashed box



Photo Image
Courtesy of US Air Force



Radar Range Equation Revisited



Parameters Affected by Transmitter/Receiver

- Radar range equation for search (S/N = signal to noise ratio)

$$S/N = \frac{P_{av} A_e t_s \sigma}{4\pi \Omega R^4 k T_s L}$$

- S/N of target can be enhanced by
 - Higher transmitted power P_{av}
 - Lower system losses L
 - Minimize system temperature T_s

P_{av} = average power
 A_e = antenna area
 t_s = scan time for Ω
 P_{av} = average power
 σ = radar cross section
 Ω = solid angle searched
 R = target range
 T_s = system temperature
 L = system loss

The design of radar transmitter/receiver affects these three parameters directly

Courtesy of MIT Lincoln Laboratory
Used with Permission



Outline

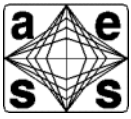

- ➔ • **Transmitters**
- **Receivers and Waveform Generators**
- **Other Transmitter / Receiver Subsystems**
- **Radar Receiver-Transmitter Architectures**
- **Summary**



Outline



- ➔ • **Transmitters**
 - Introduction
 - Block Diagram
 - High Power Tube Amplifiers
 - Klystron
 - Traveling Wave Tube
 - Crossed Field Amplifier
 - Magnetron
 - Solid State RF Power Amplifiers
 - T/R Modules
- **Receivers and Waveform Generators**
- **Other Transmitter / Receiver Subsystems**
- **Radar Receiver-Transmitter Architectures**
- **Summary**



Introduction



- **Ideal Transmitter**
 - Provides sufficient energy to detect the target
 - Easily modulated to produce desired waveforms
 - Generate stable noise free signal for good clutter rejection
 - Provide needed tunable bandwidth
 - High efficiency
 - High reliability
 - Easily maintainable
 - Long life
 - Small and light weight for the intended application
 - Affordable
- **Obviously compromise is necessary !**



Simplified Radar Transmitter/Receiver System Block Diagram

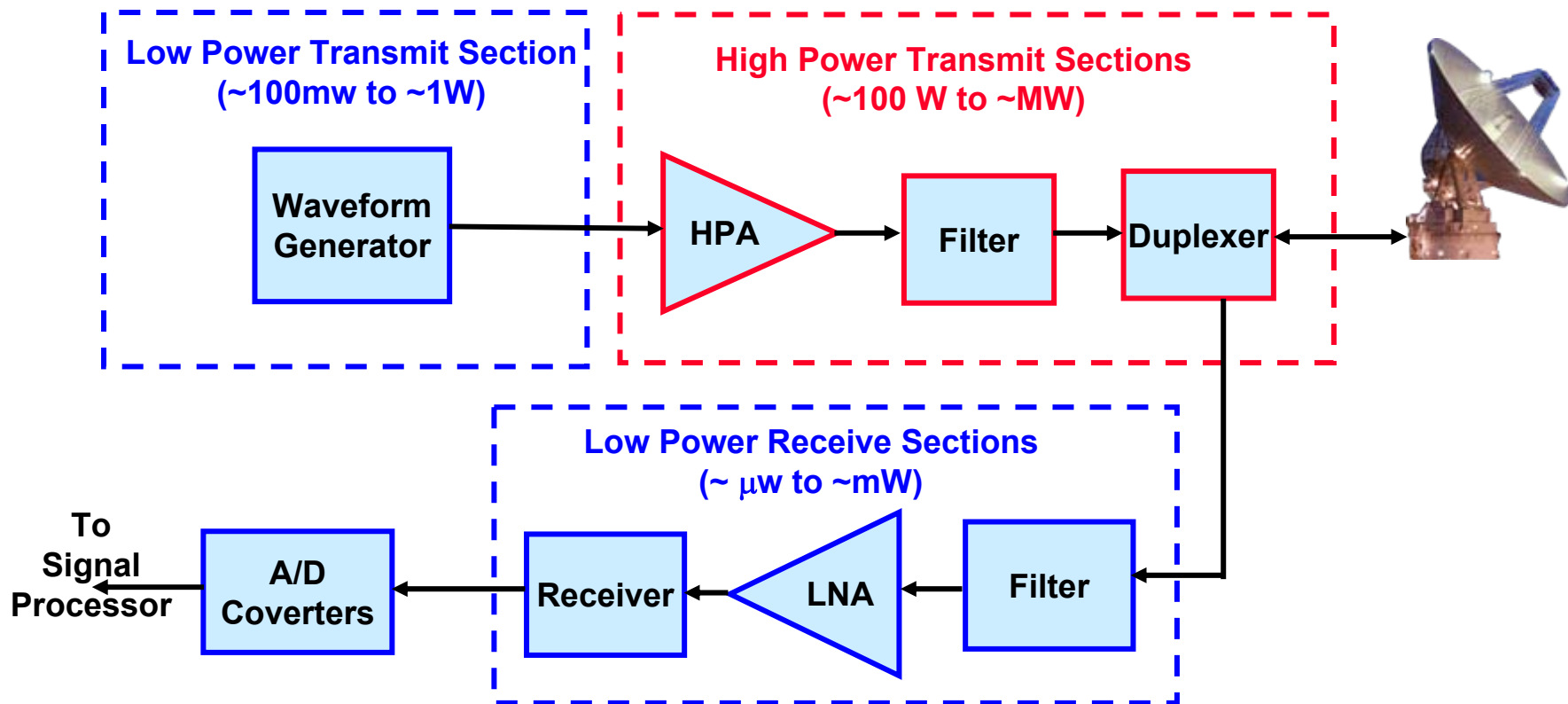

- Radar transmitter and receiver can be divided into two major subsystems:

- Low power transmit and receive sections
Radar waveform generator and receiver
- High power transmitter sections

HPA = High Power Amplifier
LNA = Low Noise Amplifier



Block Diagram of High Power Tube Transmitter

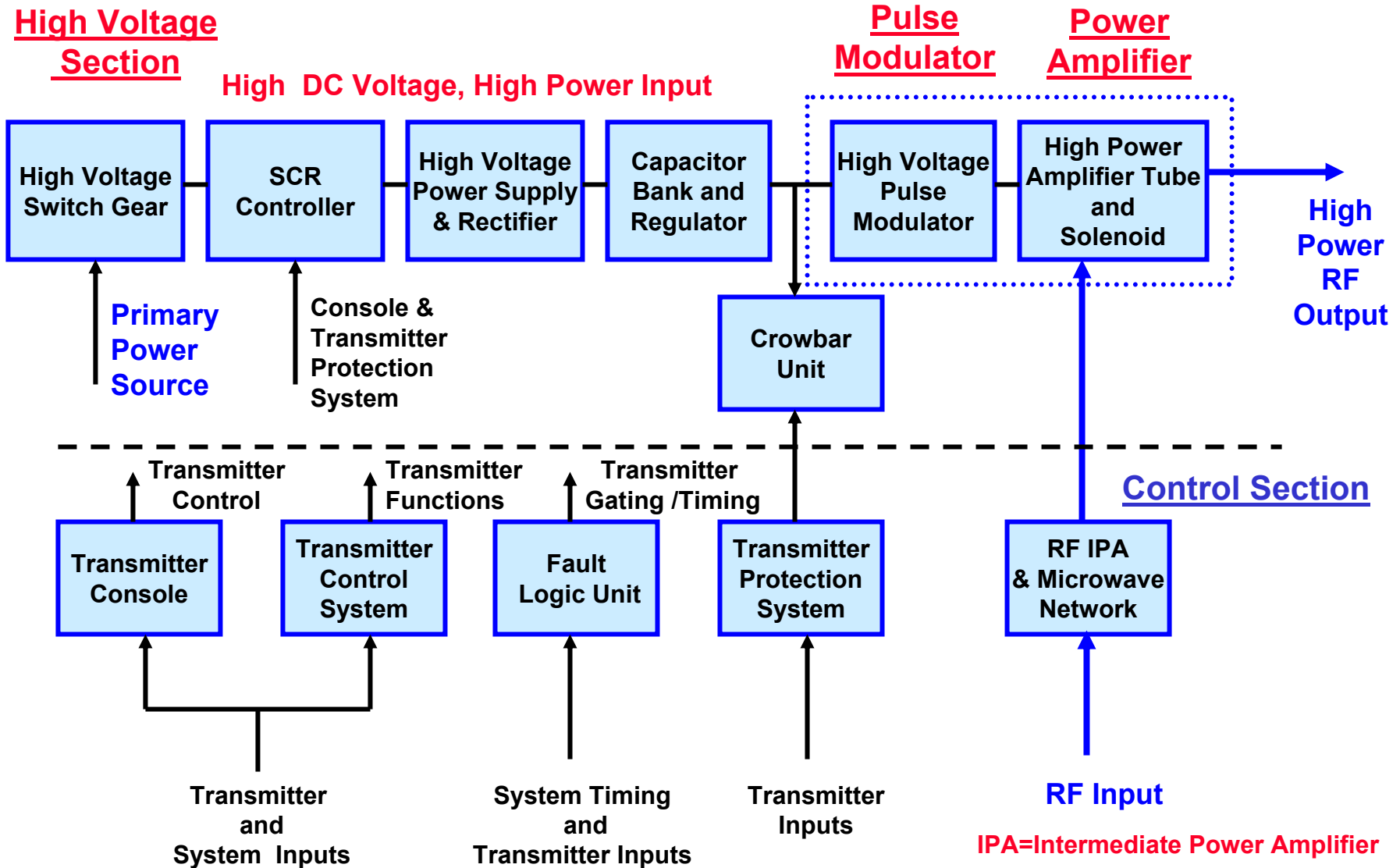



Outline



- **Introduction**
- **Transmitters**
 - **Introduction**
 - **Block Diagram**
 - – **High Power Tube Amplifiers**
 - Klystron**
 - Traveling Wave Tube**
 - Crossed Field Amplifier**
 - Magnetron**
 - **Solid State RF Power Amplifiers**
 - T/R Modules**
- **Receivers and Waveform Generators**
- **Radar Receiver-Transmitter Architectures**
- **Summary**



Klystron – High Power Amplifier



Three Cavity Klystron

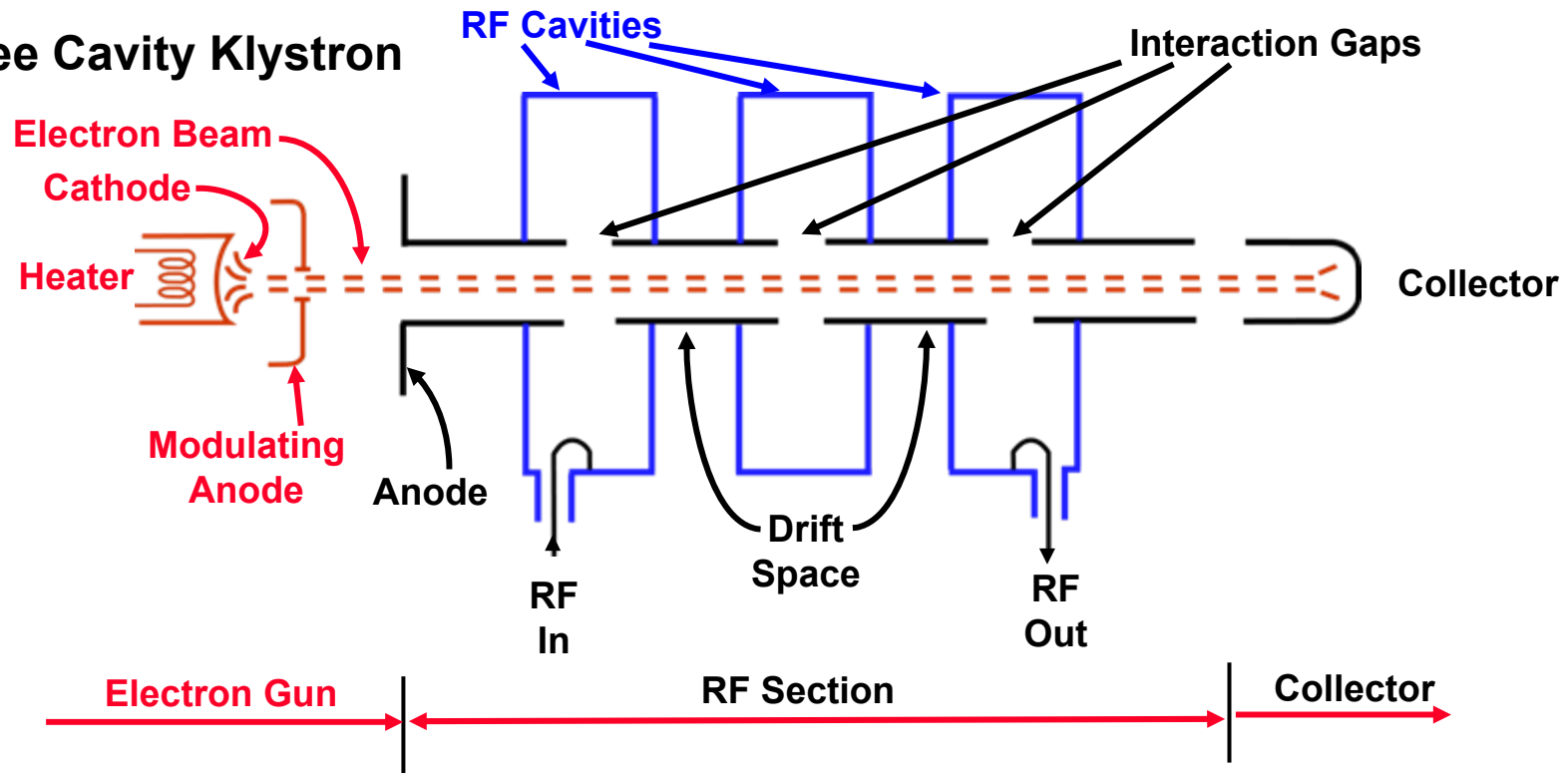

- First developed in early 1950s
- Bandwidth as great as 12%
- RF conversion efficiency 35 - 50%
- Coherent- pulse to pulse

Adapted from Skolnik
Reference 1



Klystron – How It Works

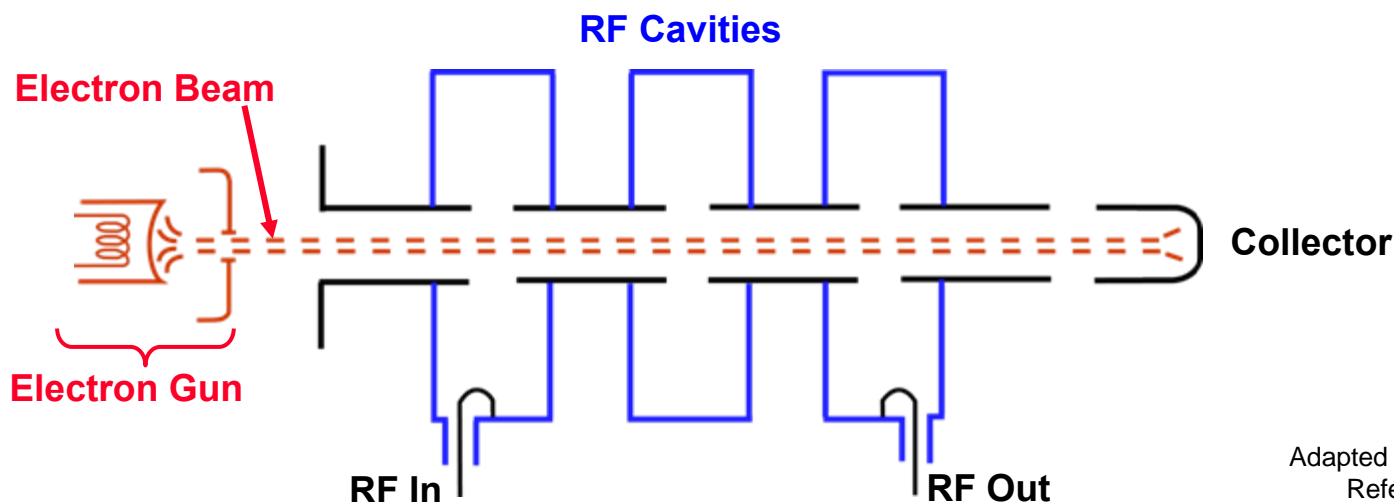

Adapted from Skolnik
Reference 1

- **Electron gun generates electron beam (X rays produced/shielding required)**
 - RF section composed of several resonators (resonant cavities)
 - RF is coupled in by waveguide through slot in cavity or coax
 - RF input is used to modulate the electron stream into bunches
 - Resonant frequency of cavity is identical to RF input frequency causing cavity to oscillate
 - Oscillations in electric field modulate speed of electron beam into bunches
 - Resonant cavity at output extracts the RF power from the density modulated beam and delivers power to output transmission line



Example – S-Band Klystron



VA-87F / VKS-8287

Air Surveillance / Weather Radar

6 cavity, S Band

Tunable over 2.7 to 2.9 GHz

Peak Power up to 2.0 MW

Ave Power up to 3 kW

Gain 50 dB Efficiency 45 %

Bandwidth 30 MHz typ.

Pulse Duration up to 7.0 μ sec



Courtesy of CPI. Used with permission.



MIT/LL Millstone Hill Radar Klystron Tubes (Vacuum Devices)

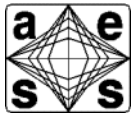

Output device	Klystrons (2)
Center Frequency	1295 MHz
Bandwidth	8 MHz
Peak Power	3 MW
Average Power	120 kW
Pulse Width	1 ms
Beam Width	0.6°
Antenna Diameter	84 ft

- Originally designed in early 1960's

Courtesy of MIT Lincoln Laboratory
Used with Permission



How Big are High Power Klystron Tubes ?



Millstone Hill Radar Transmitter Room

Courtesy of MIT Lincoln Laboratory
Used with Permission

Varian X780 Klystron

- \$400,000/tube
- 7 ft (height) x 1ft (diameter)
- 600 lbs
- 3% duty cycle
- 42 dB gain
- 600W peak input drive level

Waveguide output

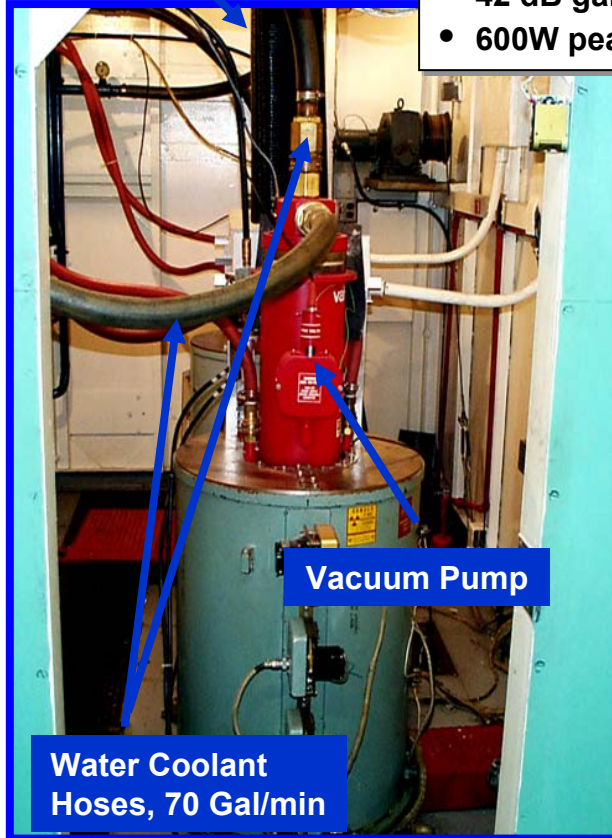

Vacuum Pump

Water Coolant
Hoses, 70 Gal/min

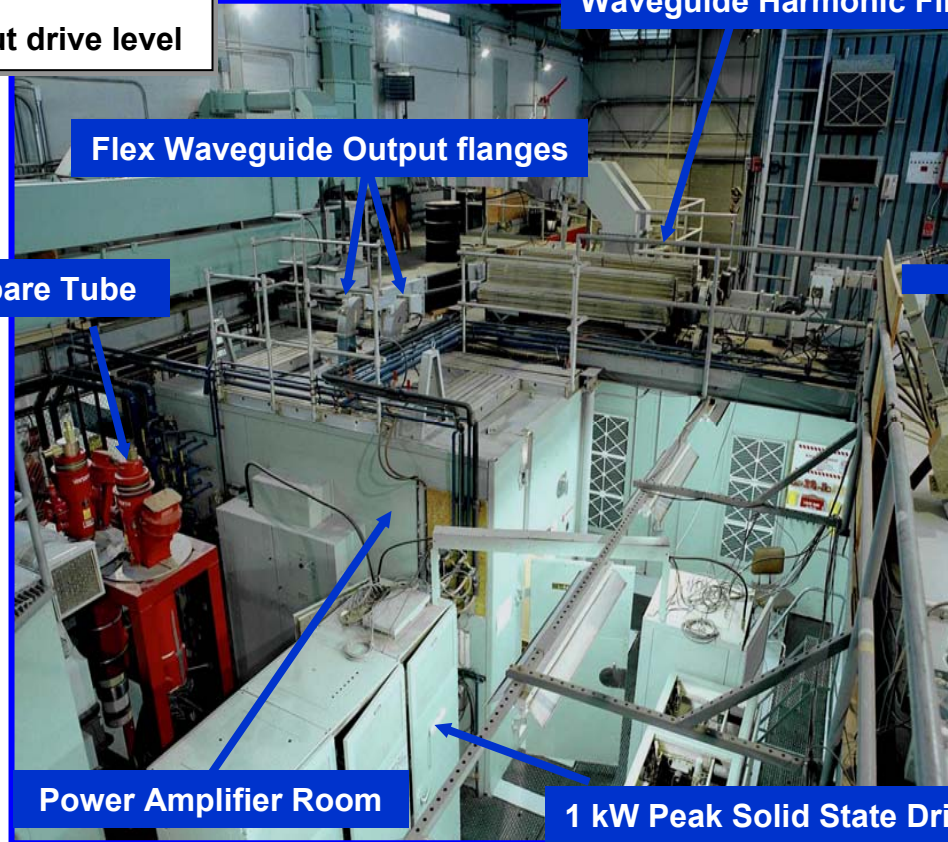

Waveguide Harmonic Filter

Flex Waveguide Output flanges

Spare Tube

200'
antenna
waveguide

Power Amplifier Room

1 kW Peak Solid State Driver Amp.



Traveling Wave Tube

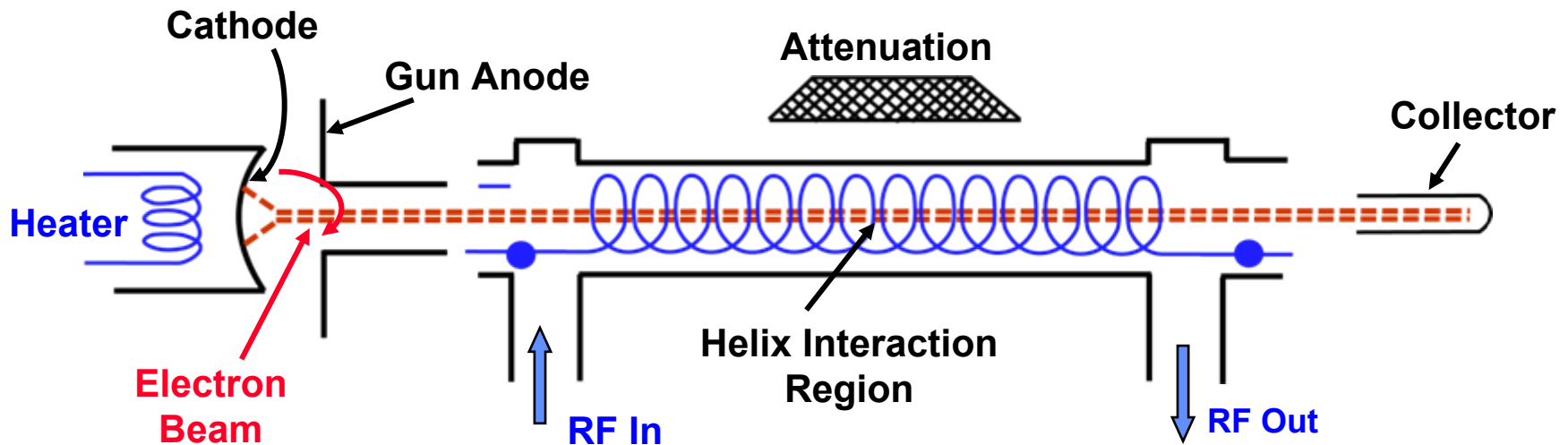

Adapted from Skolnik
Reference 1

- Capable of wide bandwidth at high power
- Expensive
- Similar to Klystron, linear beam tubes
- Interaction between RF field and electron beam over length of tube
 - RF wave mixes with electron beam and transfers DC energy from electron beam to increase energy of RF wave, causing wave to be amplified



Photograph of Traveling Wave Tubes

Another Type of Tube Amplifiers



Center Freq : 3.3 GHz
Bandwidth : 400 MHz
Peak Power : 160 kW
Duty Cycle : 8 %
Gain : 43 dB

S Band
VTS-5753
COUPLED CAVITY
TWT

X Band
VTX-5681C
COUPLED CAVITY
TWT

Center Freq : 10.0 GHz
Bandwidth : 1 GHz
Peak Power : 100 kW
Duty Cycle : 35 %
Gain : 50 dB



S-Band Transmitter



Courtesy of MIT Lincoln Laboratory
Used with Permission



Crossed Field Amplifier (CFA)

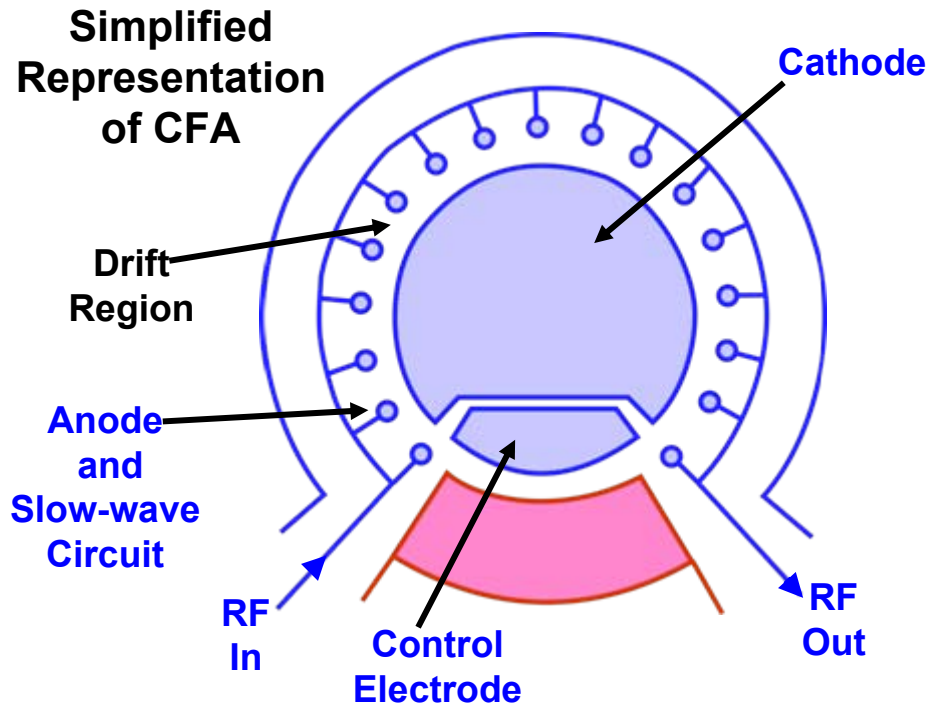

- **Capable of :**
 - High coherent power
 - Good efficiency
 - Wide bandwidth
- **Relatively low gain (10 dB)**
- **Generally noisier and less stable**
- **Resembles magnetron and employs crossed electric and magnetic fields**
 - Electrons emitted from cylindrical cathode
 - Under action of crossed electromagnetic fields, electrons form rotating bunches
 - Bunches of electrons drift in phase with RF signal and transfer their DC energy to the RF wave to produce amplification



Crossed Field Amplifier



CPI SFD 233G



Courtesy of CPI. Used with permission.

X-Band (9.0 to 9.5 GHz)

Peak Output Power 900 kW

Duty Cycle .1%

Pulsewidth 0.83 μ sec

Liquid cooled



Comparison of Different Types of High Power Amplifier Tubes



	<u>Klystron</u>	<u>Traveling Wave Tube</u>	<u>Crossed Field Amplifier</u>
Voltage	1 MW requires 90kV	1 MW requires 90kV	1 MW requires 40kV
Gain	30 - 70 dB	30 - 70 dB	8 - 30 dB
Bandwidth	1 - 8 %	10 - 35 %	10 - 15 %
X-Rays	Severe, but lead is reliable	Severe, but lead is reliable	Not a Problem
Efficiency			
Basic	15 - 30 %	15 - 30 %	35 - 45 %
With Depressed Collectors	40 - 60 %	40 - 60 %	NA
Ion Pump	Required with Large Tubes	Required with Large Tubes	Self Pumping
Weight	Higher	Higher	Lower
Size	Larger	Larger	Smaller
Cost	Medium	Higher	Medium
Spurious Noise	- dB 90	- dB 90	- dB 55 to 70
Usable Dynamic Range	40-80 dB	40-80 dB	a few dB



Coaxial Cavity Magnetron



- **Power Oscillator not an power amplifier**
- **Poor noise and stability characteristics**
 - Restricted use for MTI
- **Average power is limited**
 - 1 - 2 kilowatts
 - Good for short-medium range radars
- **Not coherent pulse to pulse**
- **Coaxial Cavity Magnetron**
- **Well suited for civil marine radars**

- **Magnetron Operation**

- Electric and magnetic field are perpendicular
- Electrons emitted from cathode travel around circular path in bunches
- Electrons interact with e-m fields and give up their DC energy to the RF field
- RF energy is output with coupling slot

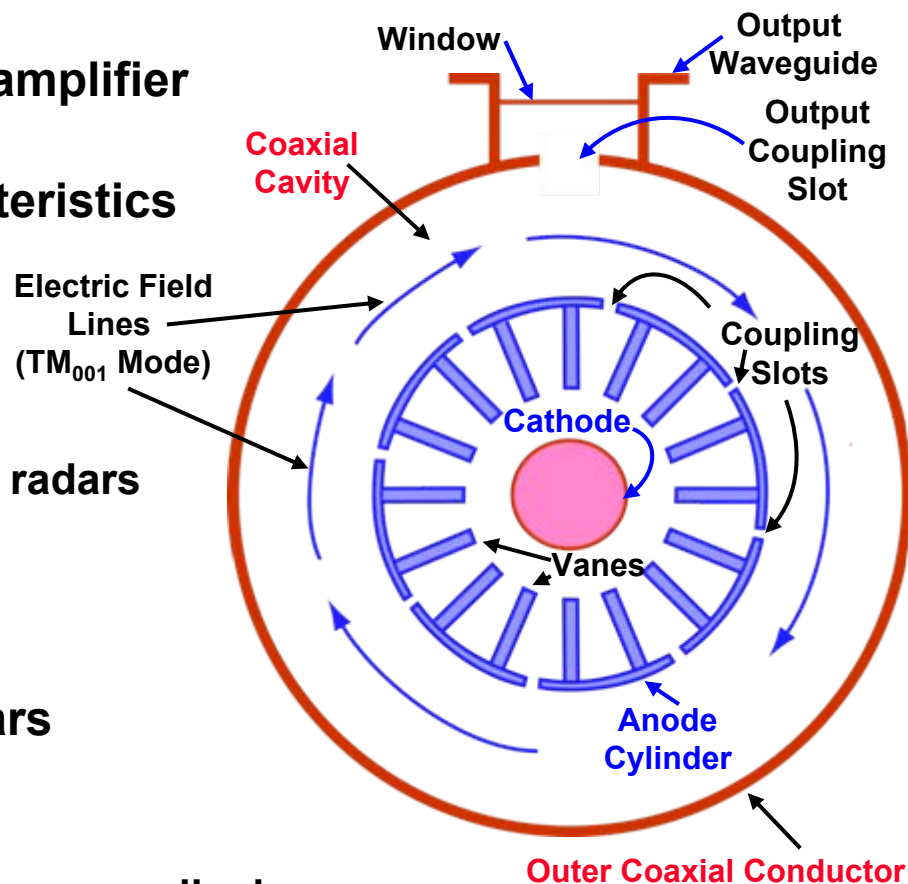

Adapted from Skolnik
Reference 3



Coaxial Magnetrons



X-Band (9.275 to 9.325 GHZ)

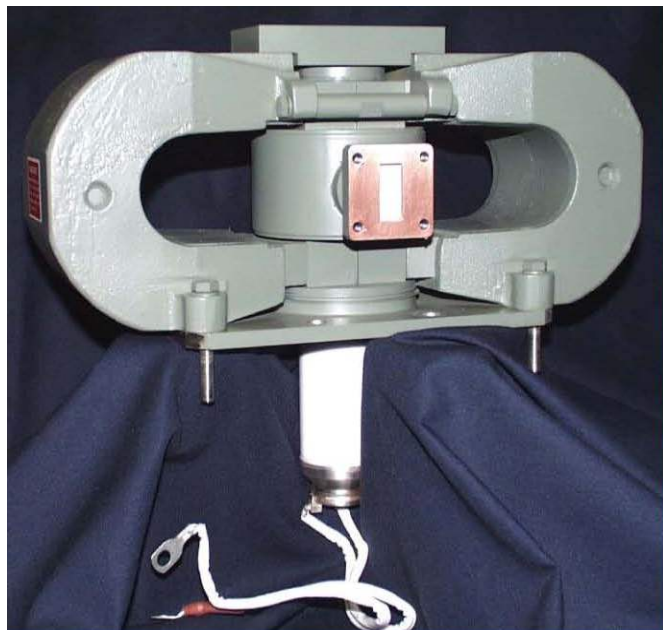

S-Band (2.7 to 2.9 GHZ)



Courtesy of CPI. Used with permission.

Model SFD 303B

**Peak Output Power 1 MW
Duty Cycle .1%
Pulsewidth 3.5 μ sec
Liquid cooled
Fixed frequency**

Model VMS 1143B

**Peak Output Power 3 MW
Duty Cycle .08%
Pulsewidth 2.0 μ sec
Liquid cooled
Mechanically tunable**



Other Types of High Power Amplifiers



- **Hybrid Klystrons**

- **Twystron, Extended interaction klystron, and Clustered cavity klystron**

Multiple cavities replace one or more of the resonant cavities

Bandwidths ~15 to 20%

Have been used in low power millimeter wave transmitters

- **Gyrotrons**

- **Require very high magnetic fields**
- **Yield very high power in millimeter region**
- **Slight use in fielded radar systems**



Outline



- **Introduction**
- **Transmitters**
 - **Block Diagram**
 - **High Power Tube Amplifiers**
 - Klystron
 - Traveling Wave Tube
 - Crossed Field Amplifier
 - Magnetron
 - – **Solid State RF Power Amplifiers**
 - T/R Modules
- **Receivers and Waveform Generators**
- **Other Transmitter / Receiver Subsystems**
- **Radar Receiver-Transmitter Architectures**
- **Summary**



Solid State Power Transistors

Available Commercial Devices

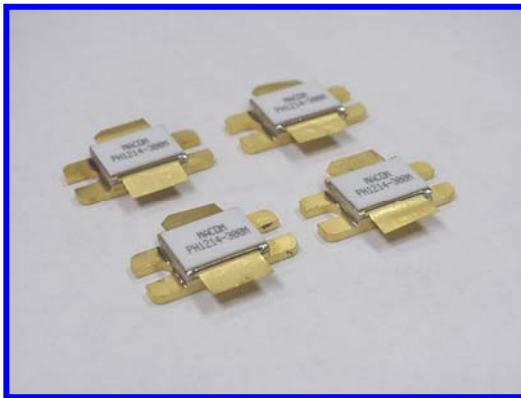

Bipolar PH3135-90S Pulsed Power Transistor
3.1-3.5 GHz, 90 W



UF28150J MOSFET Power Transistor
100-500 MHz, 150 W

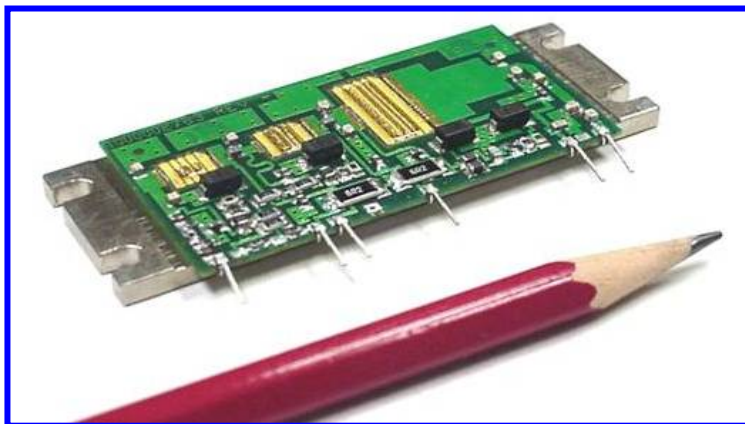

PHA2731-190M Pulsed Power Amplifier Module
190 Watts 2.7 - 3.1 GHz, 200 us Pulse, 10% Duty

- Solid state power transistors are basic building blocks of solid state amplifiers
- Advantages of solid state power amplifiers
 - Small footprint
 - Low profile
 - High reliability

Courtesy of MA/COM Technology Solutions
Used with permission



Solid State RF Power Amplifiers



- **Solid state power generation device**
 - Transistor amplifier (silicon bipolar and gallium arsenide)
- **Inherently low power and low gain**
- **Operates with low voltages and has high reliability**
- **To increase output power, transistors are operated in parallel with more than 1 stage**
- **A module might consist of 8 transistors**
 - Four in parallel as the final stage, followed by
 - Two in parallel, as the second stage, followed by
 - Two in series, as the driver stages
- **Solid state power devices cannot operate at high peak power**
 - Fifty watt average power transistor cannot operate at much more than 200 watts of peak power without overheating
 - Pulse compression needed for reasonable range resolution



Uses of Solid State Amplifiers in Radar



- **Transmitter for low power application**
- **High power transmitter**
 - A large number of microwave transistors are combined with microwave circuitry
- **Many modules distributed on a mechanically steered planar array**
 - A “3 D” radar
- **A module at each of the many elements of an electronically scanned phased array**
 - Called an “active aperture”



Solid State Radar Examples - PAVE PAWS



- **PAVE PAWS**

- First all solid state active aperture electronically steered phased array radar
- UHF Band , detection and warning of sea launched missile attack
- 1792 active transceiver T / R modules, 340 w of peak power each

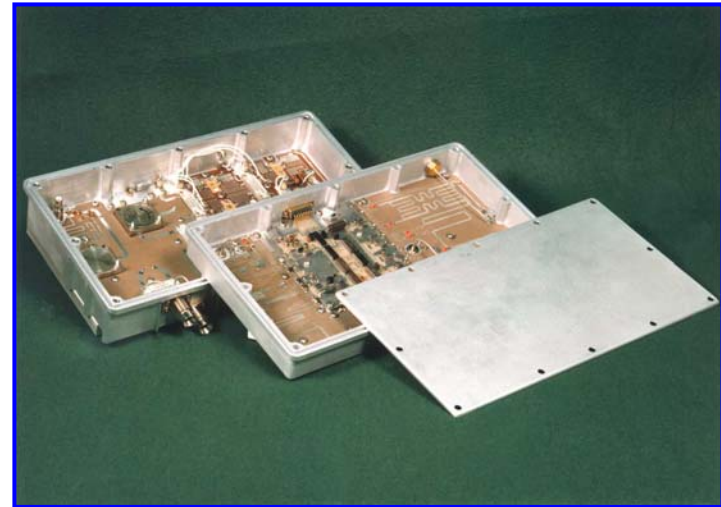

Courtesy of Raytheon
Used with Permission



Solid State Radar Examples - TPS-59



TPS-59



- Air surveillance radar developed for the US Marine Corps
- Rotating planar L-Band array
30 ft by 15 ft
- Each transmitter module has 10 of 100 watt amplifier units consisting of two 55 watt silicon bipolar transistors (7 watts of gain) driven by a smaller 25 watt device
- Each transmitter module feeds one of 54 rows



Courtesy of Lockheed Martin
Used with Permission



Solid State Radar Examples - RAMP



- **Radar Modernization Project (RAMP)**
 - **L-Band air traffic control surveillance radar developed for Canada by Raytheon Canada**
 - **Solid state transmitter with peak power of 28 kW (7% duty cycle)**
 - **14 modules, each consists of 42 - 100 watt peak power silicon bipolar transistors in 2-8-32 configuration**
 - RF amplifier modules combined in pairs-- > 7 of these combined -- > 1 transmitter**
 - Only 6 needed to meet sensitivity requirement**

RAMP Radar



Transmitter Cabinet



Solid State Transmitter Module

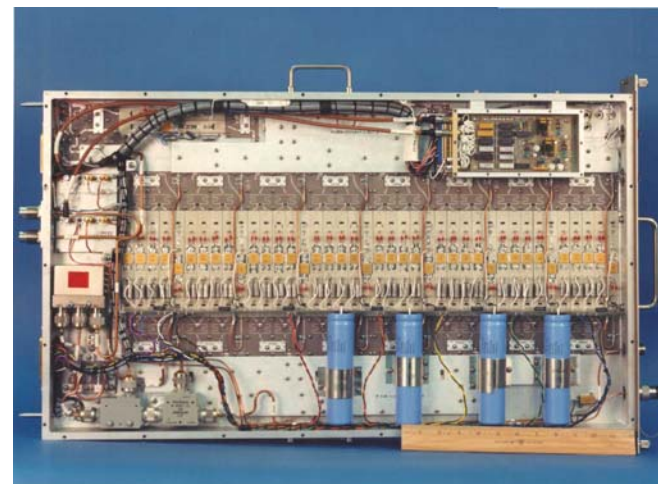

Courtesy of Raytheon
Used with Permission



Example of Solid State Transmitter



Radar Surveillance Technology Experimental Radar (RSTER)

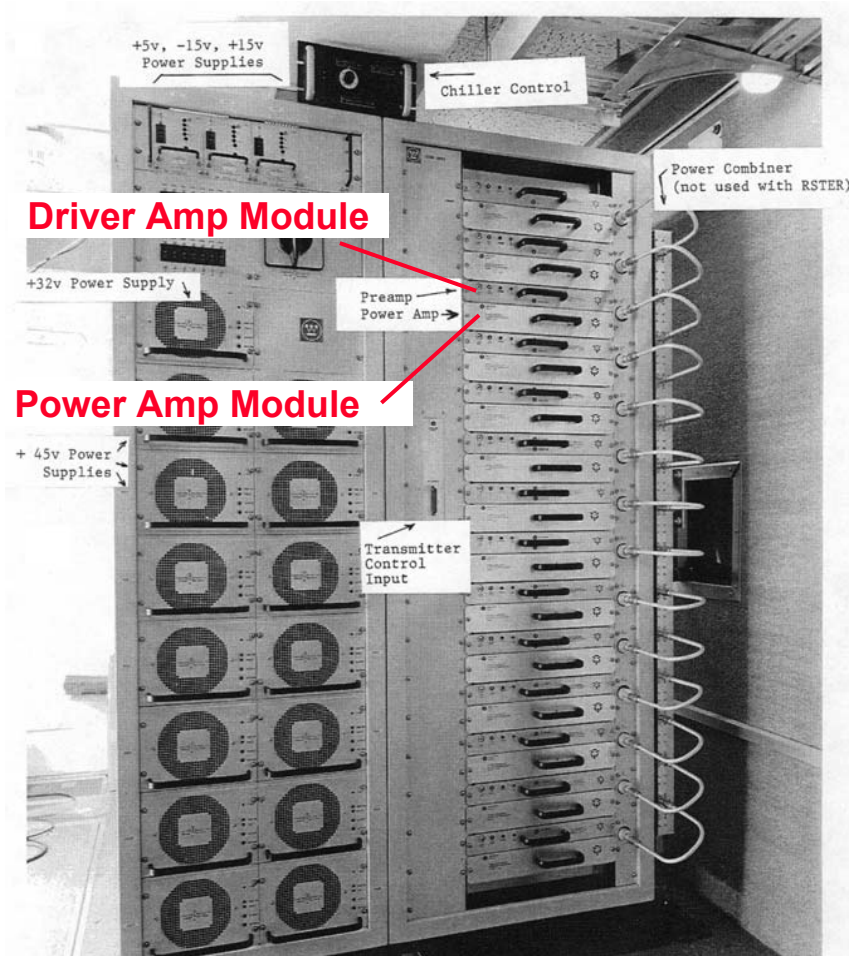

- 14 channels with 140 kW total peak power
 - 8 kW average power
- Each channel is supplied by a power amplifier module
 - 10 kW peak power

Courtesy of MIT Lincoln Laboratory
Used with Permission



Average Power Output Versus Frequency



Tube Amplifiers versus Solid State Amplifiers

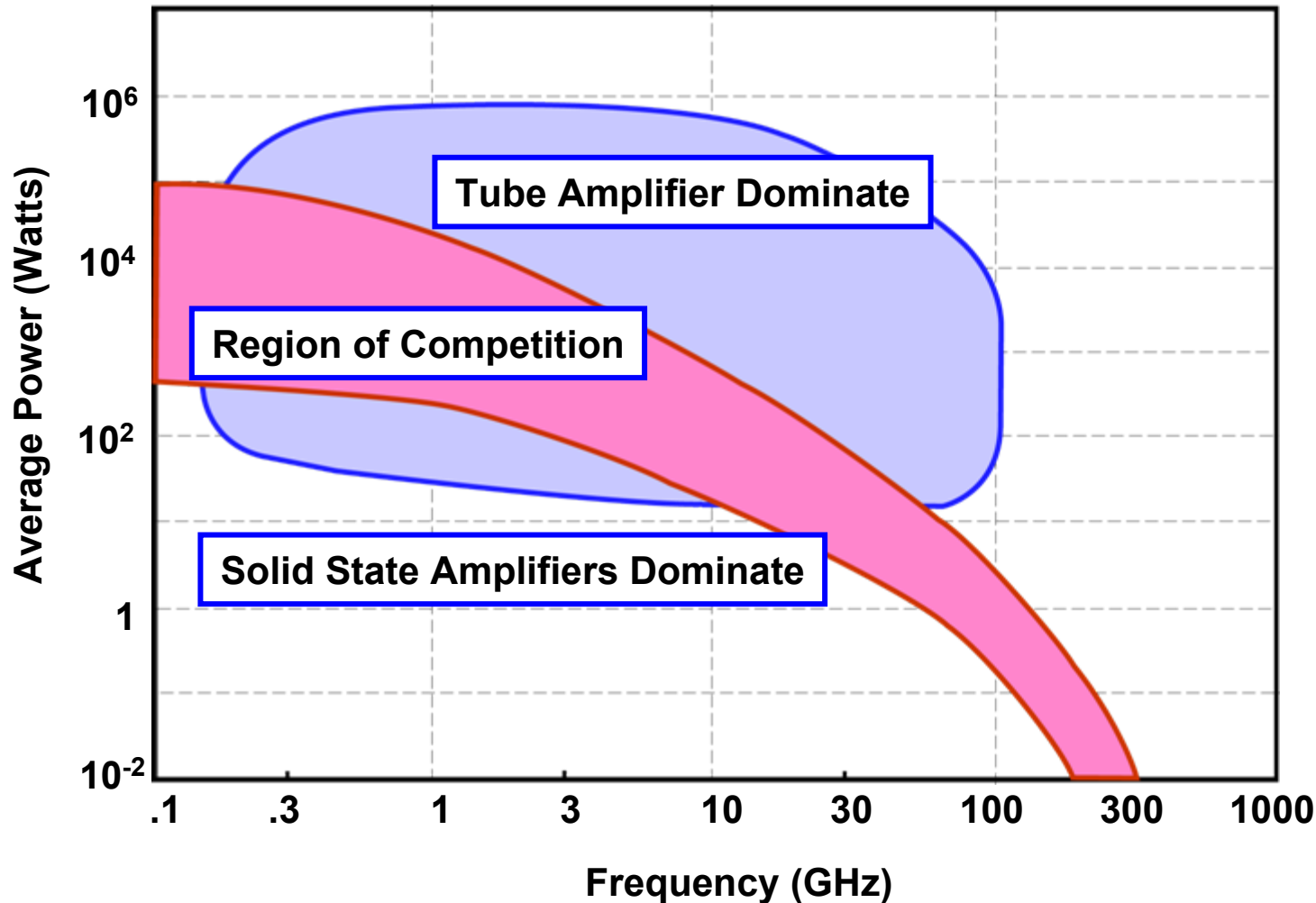



Types of High Power Amplifiers



- Vacuum tube amplifiers and solid state amplifiers

	Vacuum Tube Amplifiers	Solid State Amplifiers
Output Power	High (10 kW to 1 MW)	Low (10's to 100's W)
Cost per Unit	High (\$10's K to \$300 K)	Low (\$100's)
Cost per Watt	\$1 – 3	Varied
Size	Bulky and heavy	Small foot print
Applications	<ul style="list-style-type: none">• Dish antenna• Passive array	<ul style="list-style-type: none">• Active array• Digital array

Courtesy of MIT Lincoln Laboratory
Used with Permission



Methods of Power Amplification



- **Tube amplifiers**
 - Klystrons
 - Travelling wave tubes
 - CFAs
- **Solid State amplifiers**
 - Solid state power transistors

Issues to be traded off in choice of high power amplifier

- Average power output at desired operating frequency
- Amplifier efficiency
- Instantaneous and tunable bandwidth
- Duty cycle
- Gain
- Reliability
- Cost



Outline

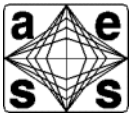

- Introduction
- Transmitters
- • Receivers and Waveform Generators
- Other Transmitter / Receiver Subsystems
- Radar Receiver-Transmitter Architectures
- Summary



Radar Transmitter/Receiver Timeline

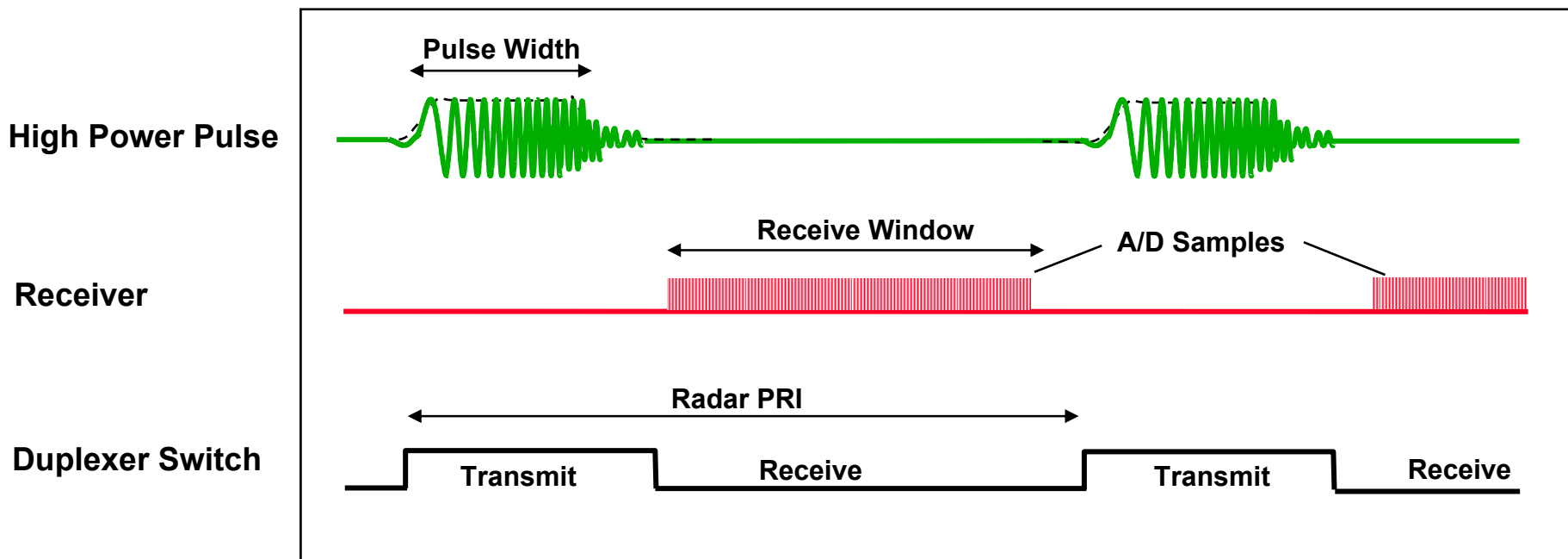

- **Sensitive radar receiver must be isolated from the powerful radar transmitter**
 - Transmitted power typically 10 kW – 1 MW
 - Receiver signal power in 10's μ W – 1 mW
- **Isolation provided by duplexer switching**

PRI = Pulse Repetition Interval

Courtesy of MIT Lincoln Laboratory
Used with Permission



Radar Receiver



- **Purpose is to extract the weak radar echo signal from the antenna and to amplify it**
 - **Pass to signal processor for Doppler / pulse compression processing**
- **Employs matched filter to maximize peak signal to mean noise**
- **Target presence decision made by computer**
- **Most are superhetrodyne receivers**
 - **RF input to IF**
 - Easier to obtain matched filter shape, bandwidth gain, and stability**
 - **First stage of front end of receiver is a low noise amplifier**
 - Usually a transistor**
 - **Sensitivity Time Control (STC) is usually in the receiver**



Shared Functionality in Waveform Generation and Receiver

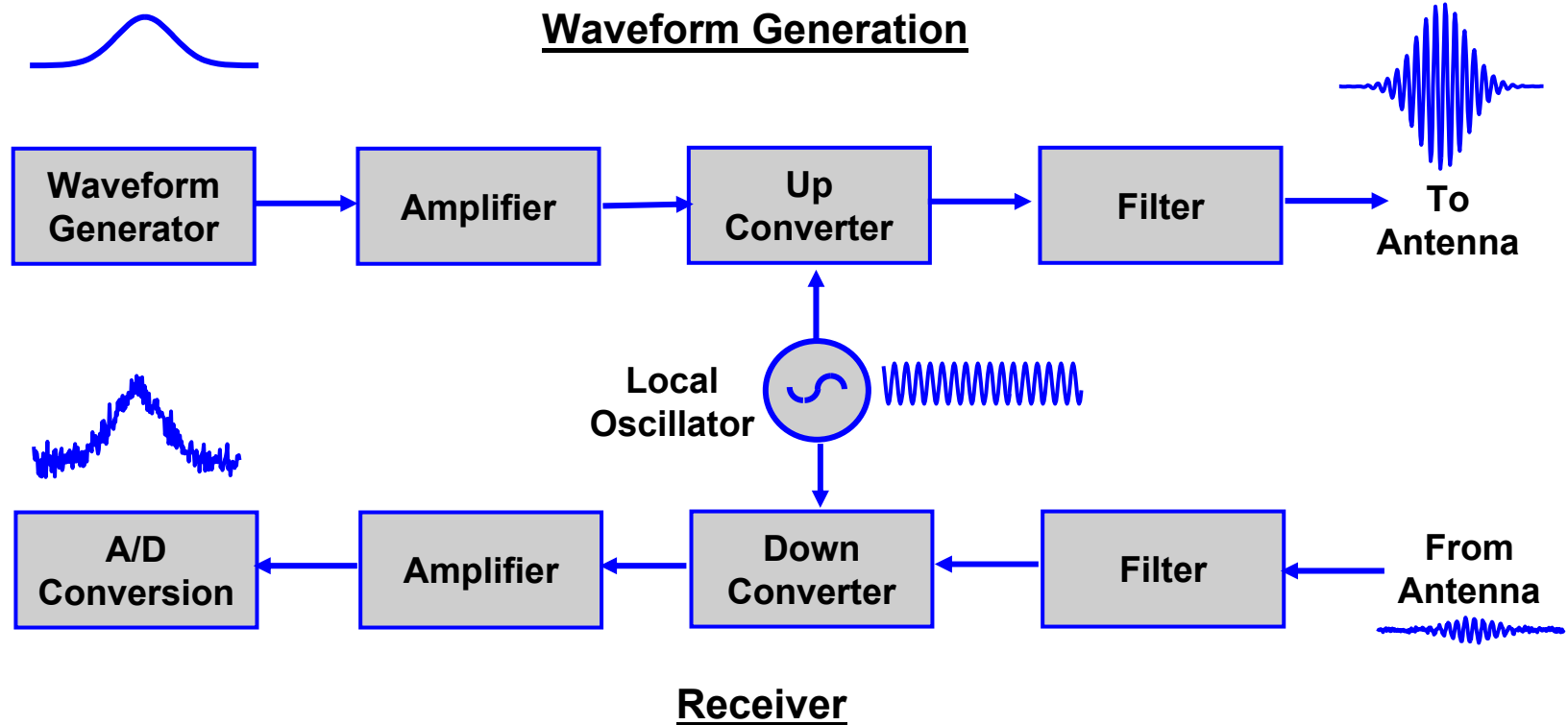
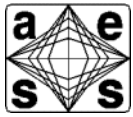

- **Waveform generator and receiver share several similar features**
 - **Frequency conversion, and amplification, and filtering**



Radar Frequency Conversion Concepts



Waveform Generation

Frequency Upconversion
Baseband to S Band

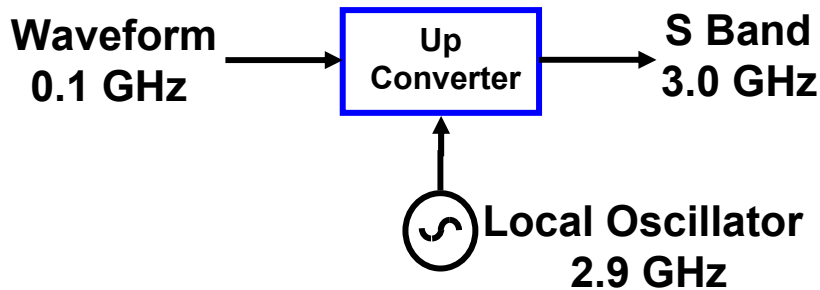

- Upconverter shifts the waveform frequency to a higher frequency
- Reason:
 - Waveform generation less costly at lower a frequency

Receiver

Frequency Downconversion
S Band to Baseband

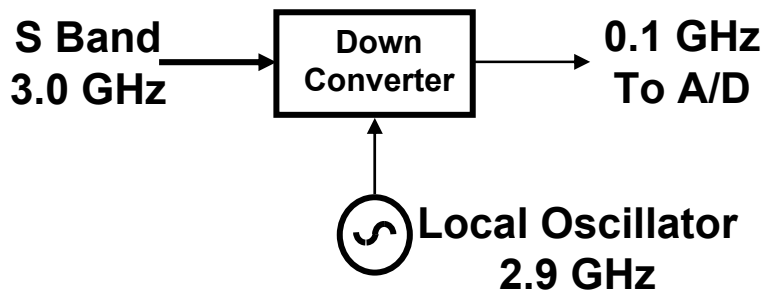

- Downconverter shifts the receive frequency to a lower frequency
- Reason:
 - High dynamic range of A/D converter is easier to achieve at lower frequency



Simplified Block Diagram of Waveform Generation and Receiver

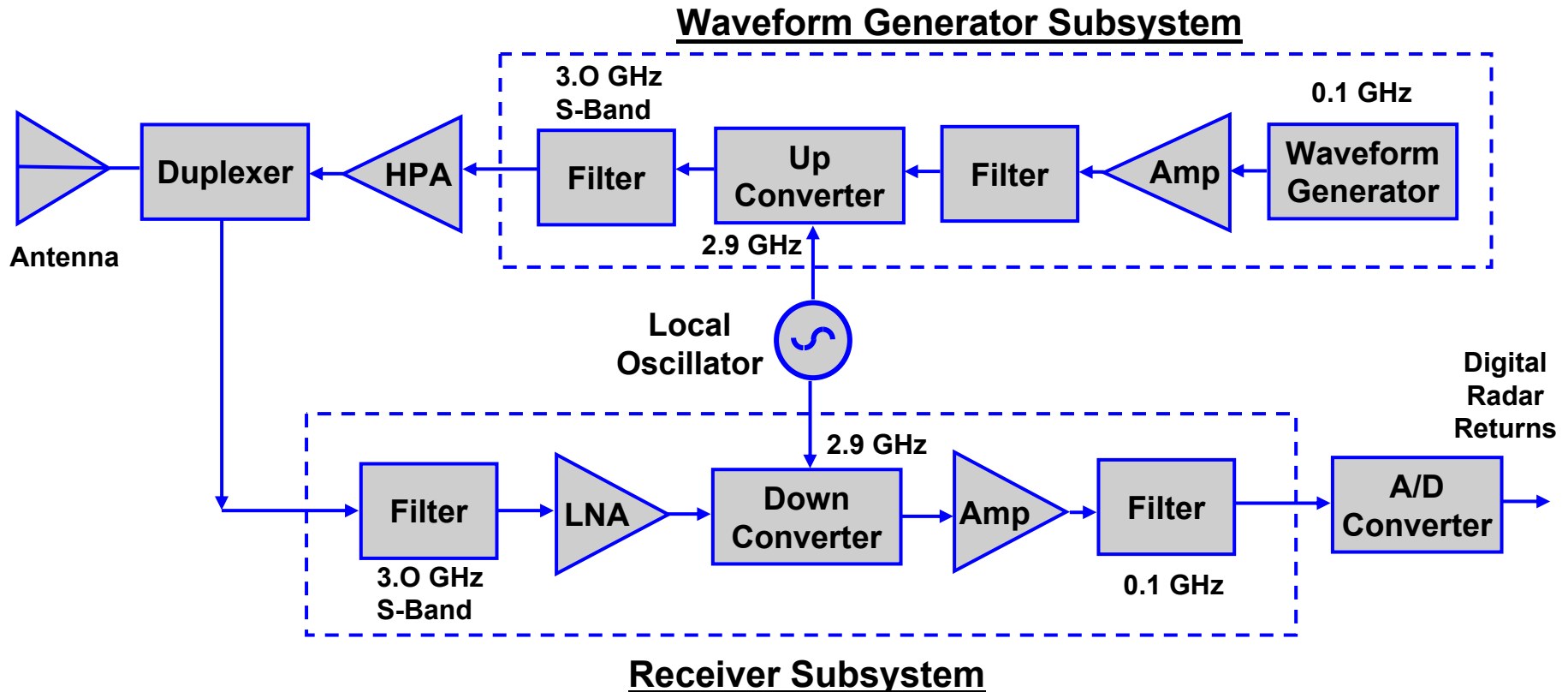
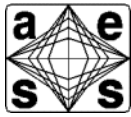

- Only one stage of conversion is illustrated
 - Usually, multiple stages of frequency conversion, filtering, and amplification are utilized

HPA = High Power Amplifier
LNA = Low Noise Amplifier
Amp = Amplifier



Block Diagram of Radar Receiver

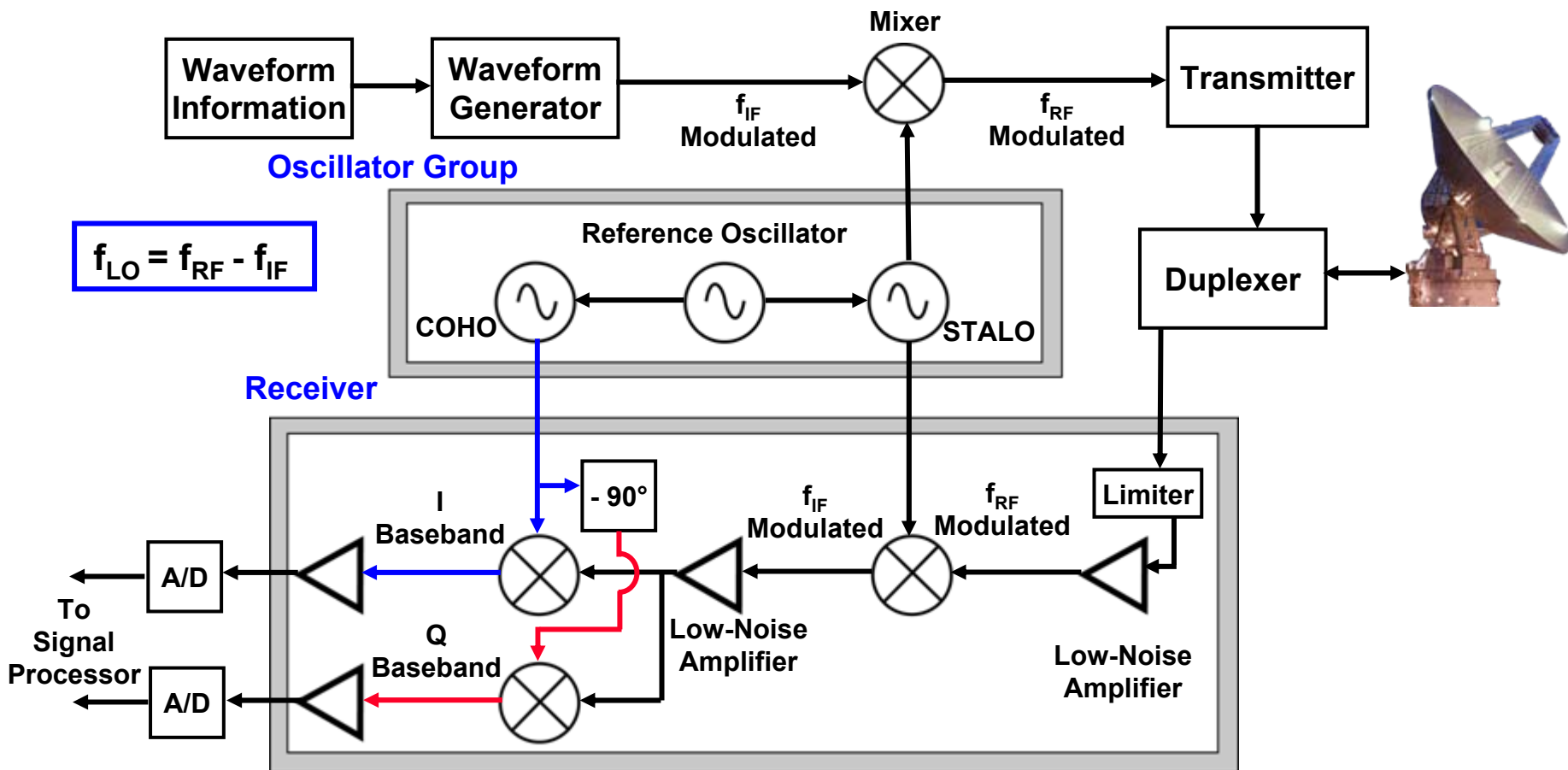

Components from the Antenna to the First Amplifier are the most Important in Determining the Noise Level of a Radar Measurement



Outline



- Introduction
- Transmitters
- Receivers and Waveform Generators
- ➔ • Other Transmitter / Receiver Subsystems
- Radar Receiver-Transmitter Architectures
- Summary



Other Transmitter Subsystems / Components



- ➔ ● **Duplexers**

- **Other Transmitter Subsystems**
 - Pulse Modulators
 - “Crowbar”

- **Waveguide and Transmission Lines**

- **Other Stuff**



How a Duplexer Works



Transmitter On

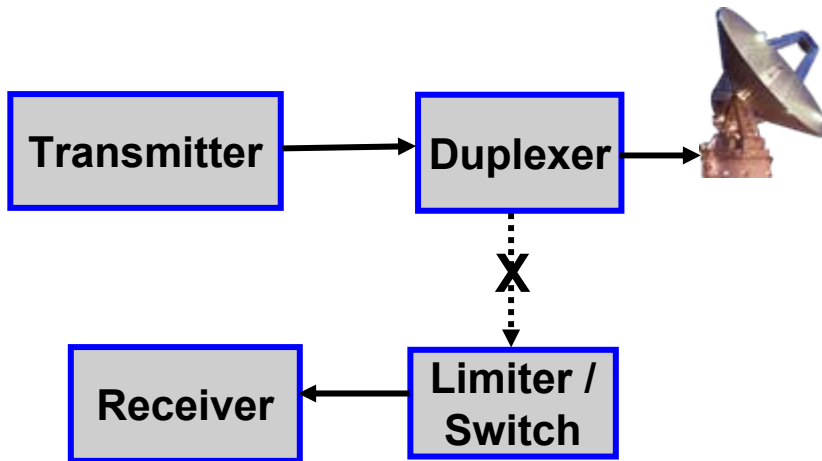

Transmitter Off

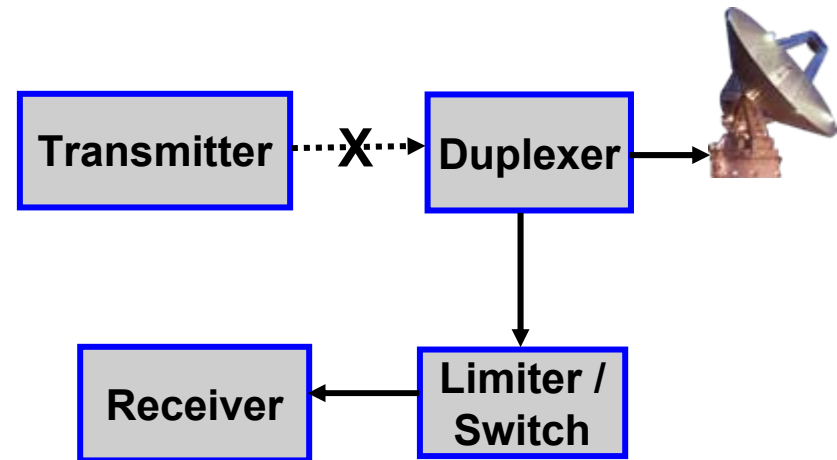

- Transmitter and antenna connected with low loss
- Receiver protected while transmitter is transmitting RF

- Receiver and antenna connected with low loss
- Limiter/ receiver protector is employed for additional protection against strong interference or transmitter feed through



Duplexer



- **A fast acting switching device which allows a pulse radar to time share a single antenna with a receiver and a transmitter**
 - On transmission, the duplexer protects receiver from damage or burnout
 - On reception, channels the receive echo to the receiver and not to the transmitter
 - Must be done quickly, in microseconds or nanoseconds
- **For high power radars, the duplexer is T/R switch (a gas discharge device)**
 - High power pulse from transmitter causes gas discharge device to break down and short circuit the receiver to protect it from damage
 - On receive, the RF circuitry of the duplexer directs the echo signal to the receiver rather than the transmitter
 - Need 60 - 70 dB of Isolation with negligible loss
 - e.g. transmitter power (~megawatt); receiver signal (~1 watt)



Example - Balanced Duplexer

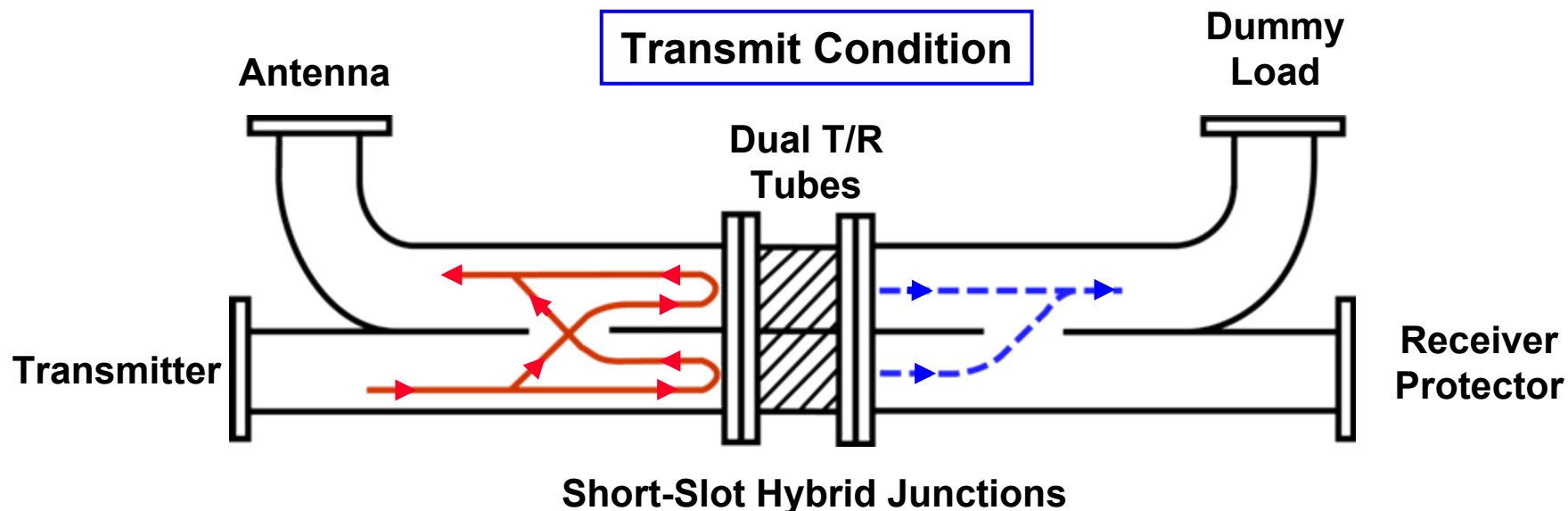

- The duplexer cannot always do the entire job of protecting the receiver
- Diode or ferrite limiters are used to additionally protect the receiver
 - Also to protect receiver from radiation from other radars that do not activate the duplexer



Example - Balanced Duplexer

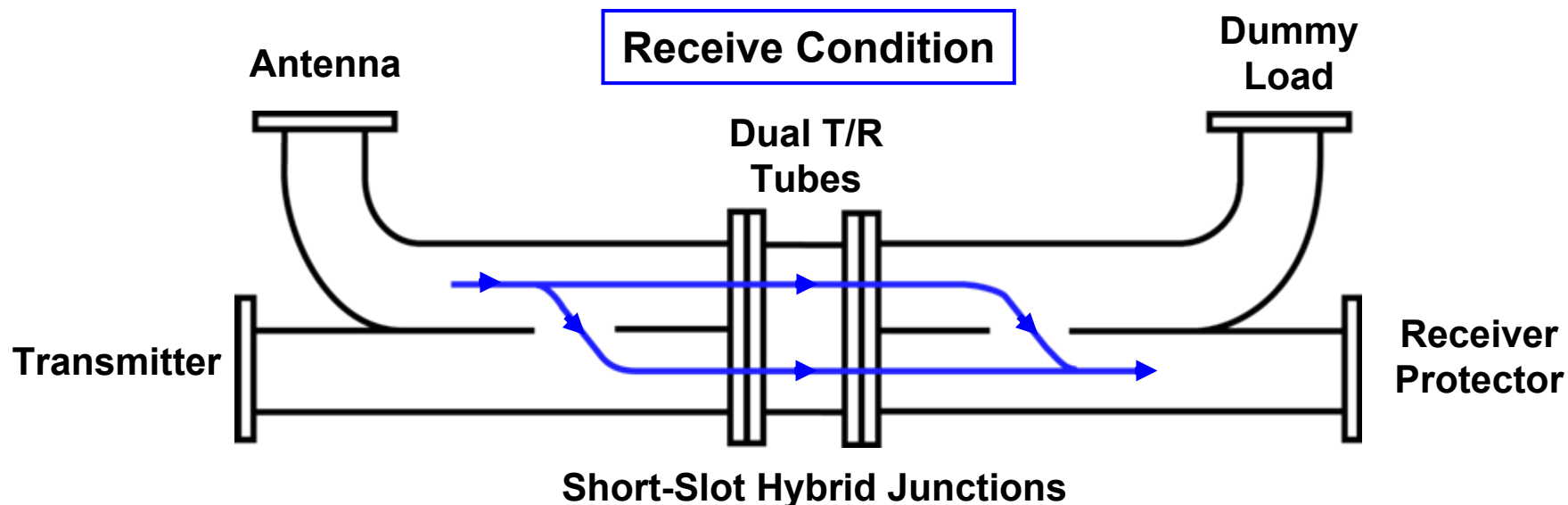

- The duplexer cannot always do the entire job of protecting the receiver
- Diode or ferrite limiters are used to additionally protect the receiver
 - Also to protect receiver from radiation from other radars that do not activate the duplexer



Other Transmitter Subsystems / Components



- Duplexers
- • Other Transmitter Subsystems
 - Pulse Modulators
 - “Crowbar”
- Waveguide and Transmission Lines
- Other Stuff



Basic Elements of Pulse Modulator

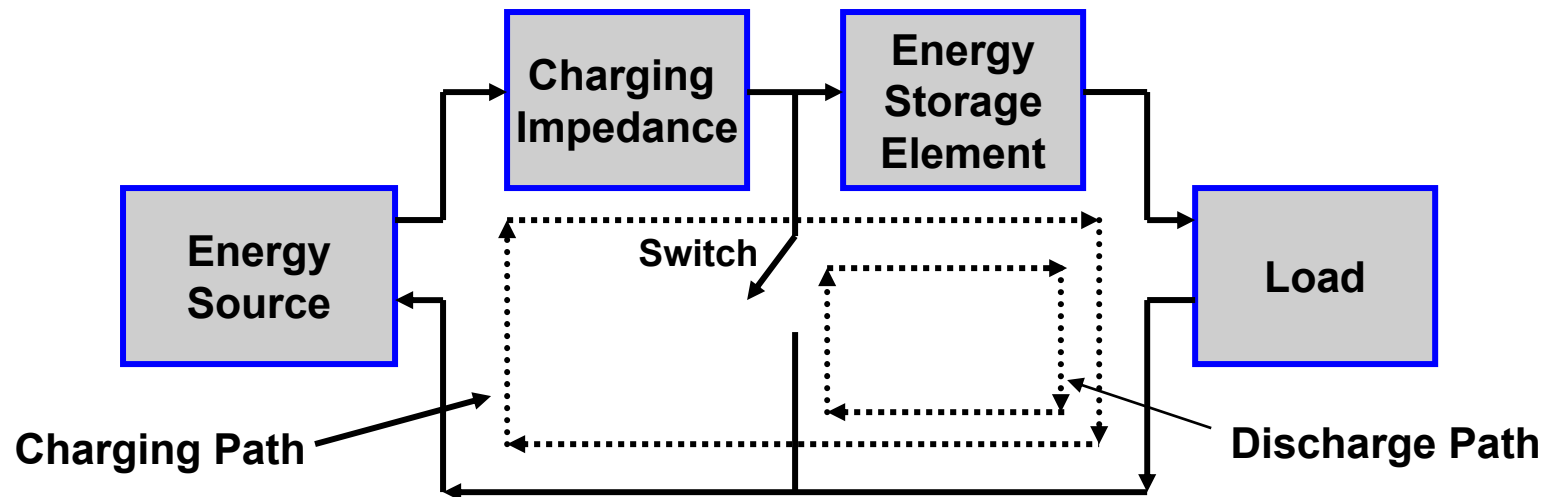

- The function of the modulator is to turn the transmitter on and off to generate the desired waveform
 - Energy from an external source is accumulated in the energy storage element at a slow rate
 - When the pulse is ready to be formed, the switch is closed and the stored energy is quickly discharged through the load to form the dc pulse that is applied to the RF power device
 - During discharge the charging impedance prevents the energy from being returned to the energy source

Adapted from Skolnik
Reference 1



“Crowbars”



- **Power amplifier tubes can develop internal arc discharges with little warning!**
 - Capacitor bank discharges large currents through the arc
 - Tube can be damaged
- **Crowbar device places short circuit across capacitor bank to transfer its stored energy.**
- **When a sudden surge of current due to a fault in a protected power tube is sensed, the crowbar switch is activated within a few microseconds.**
- **The current surge also causes the circuit breaker to open and de-energize the primary source of power.**



Other Transmitter Subsystems / Components



- **Duplexers**
- **Other Transmitter Subsystems**
 - **Pulse Modulators**
 - **Crowbar Function**
- ➔ • **Waveguide and Transmission Lines**
- **Other Stuff**



Different Waveguide Configurations

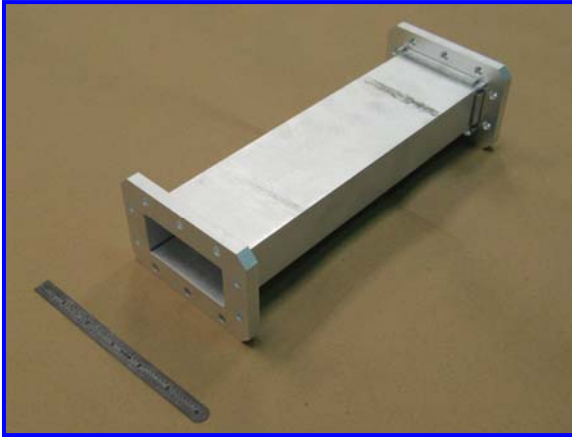

L Band Rectangular Waveguide

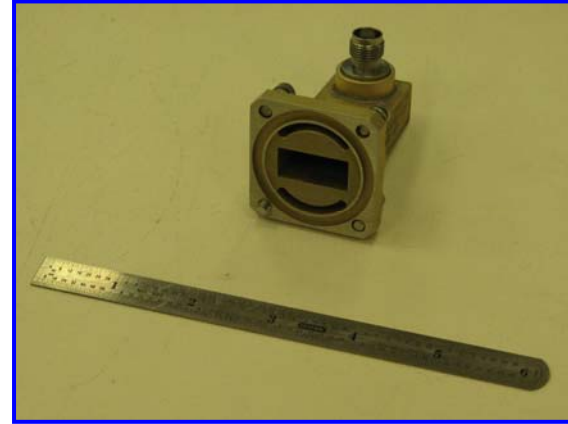

X Band Coax to Waveguide Adapter



**C Band
90° E Field & H field Bend**



**C Band 90°
Twist
Waveguide**

Courtesy of Cobham Sensor Systems.
Used with permission.



Flexible and Ridged Waveguide

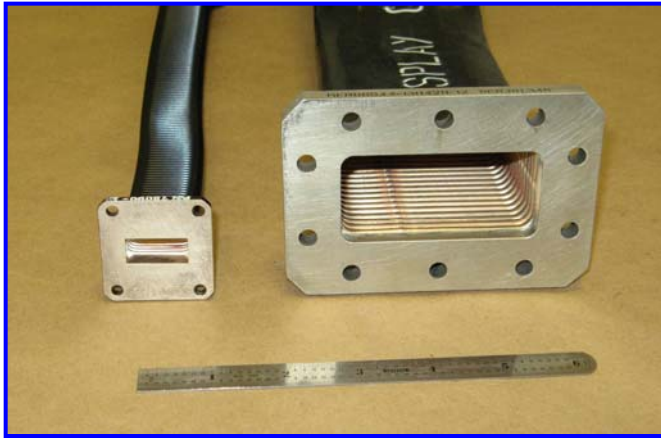

X Band & S Band Flexible Waveguide

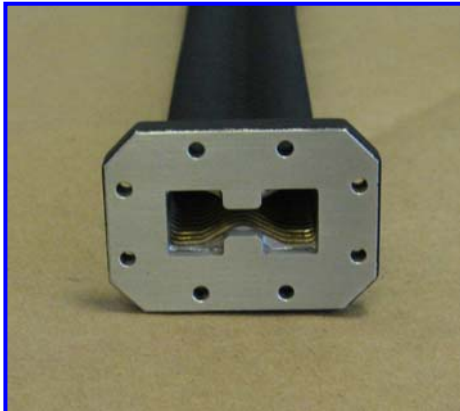

X Band Ridged Waveguide



C Band Flexible Waveguide

Adding the ridges to the waveguide increases its bandwidth of operation

Courtesy of Cobham Sensor Systems
Used with permission.



Waveguide Cutoff Wavelength / Frequency



- The lower cutoff frequency for a particular mode (T_{mn}) in a rectangular wave guide is given by:

$$f_c = \frac{1}{2\sqrt{\epsilon\mu}} \sqrt{\left(\frac{m}{a}\right)^2 + \left(\frac{n}{b}\right)^2}$$

- where
 - f_c = cutoff frequency in Hz
 - a = width of waveguide
 - b = height of waveguide
 - μ_0 = permeability of free space
 - ϵ_0 = permittivity of free space
 - m = integers 0, 1, 2, 3,
 - n = integers 0, 1, 2, 3,

C Band Flexible Waveguide

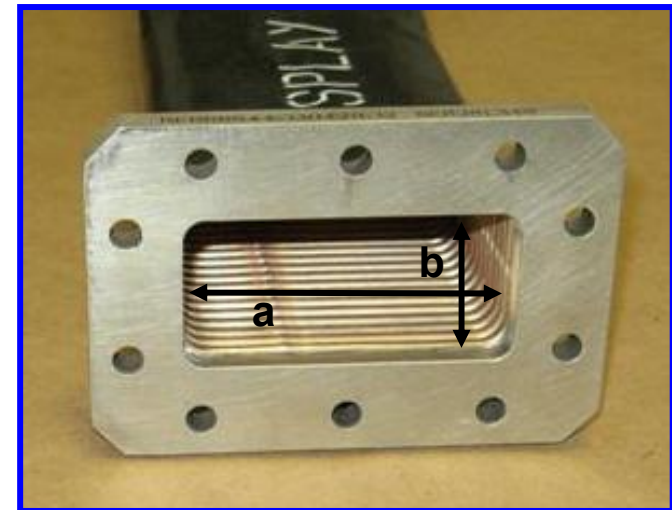

Courtesy of Cobham Sensor Systems.
Used with permission.



Waveguide Subsystems

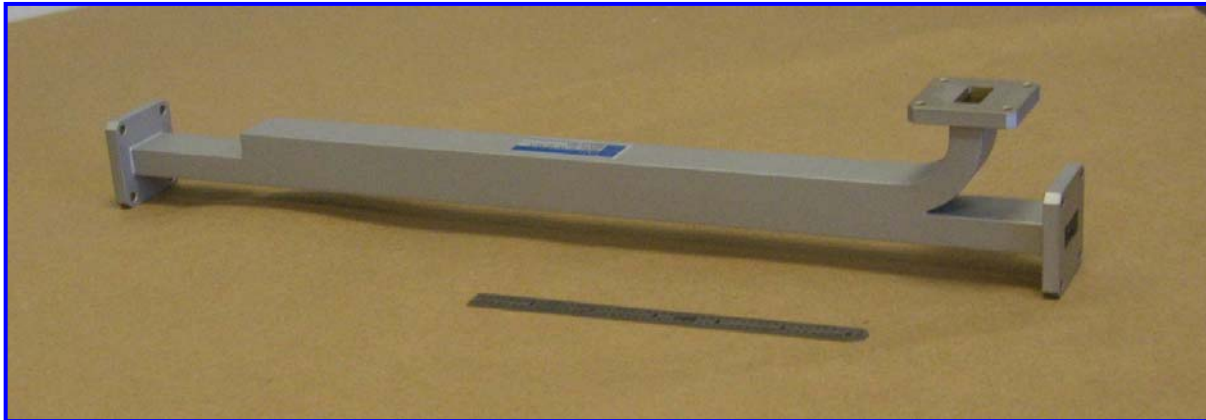

X Band Directional Coupler

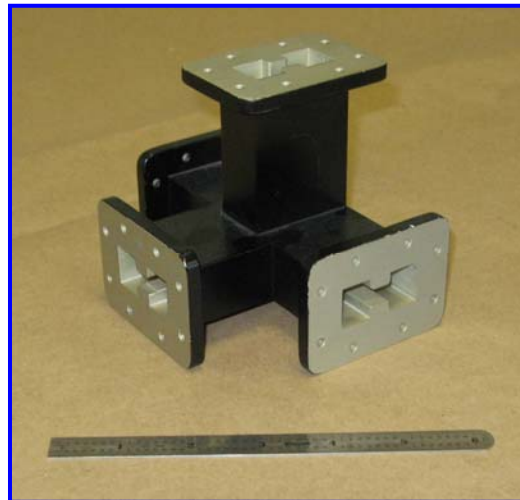

**C Band Ridged
"Magic T"**

Courtesy of Cobham Sensor Systems.
Used with permission.



Rotary Joint

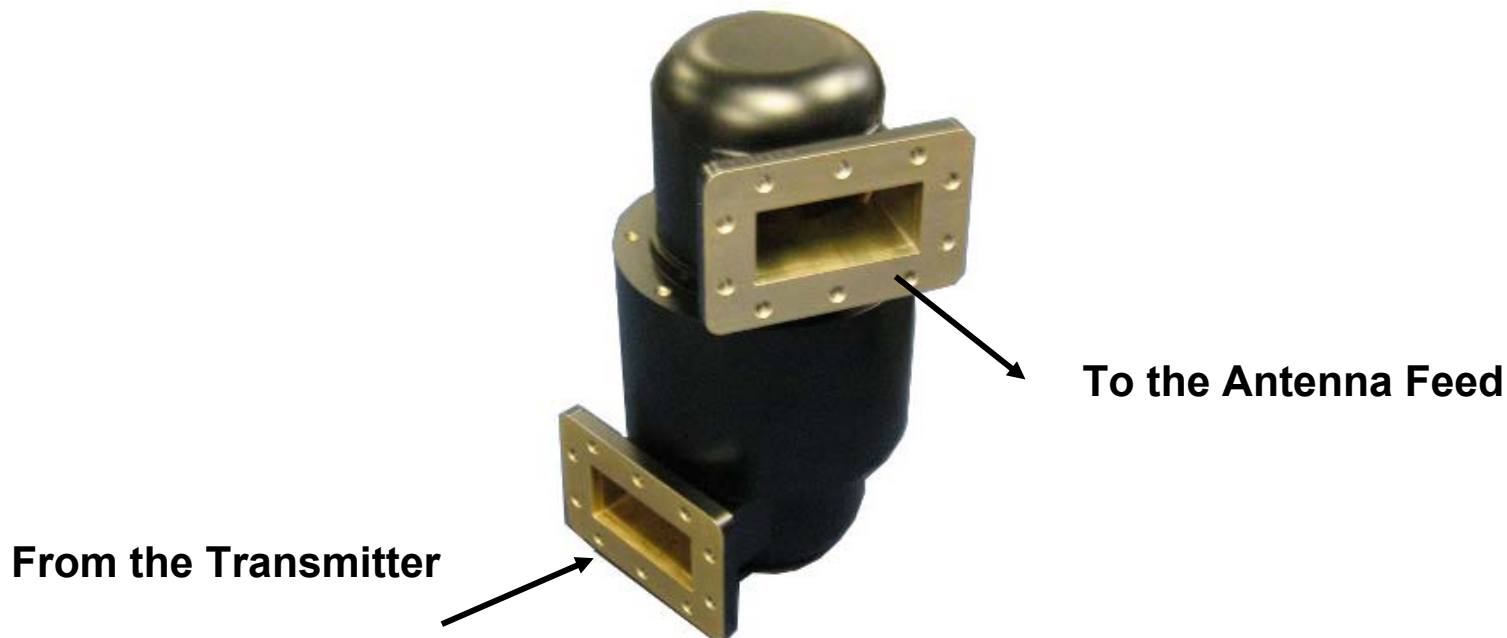

Courtesy of Mega RF Solutions

- A rotary joint couples the microwave energy from the transmitter to the antenna feed as the antenna rotates
- It is located in the base of an antenna, which rotates about a vertical axis



Stripline Transmission Line

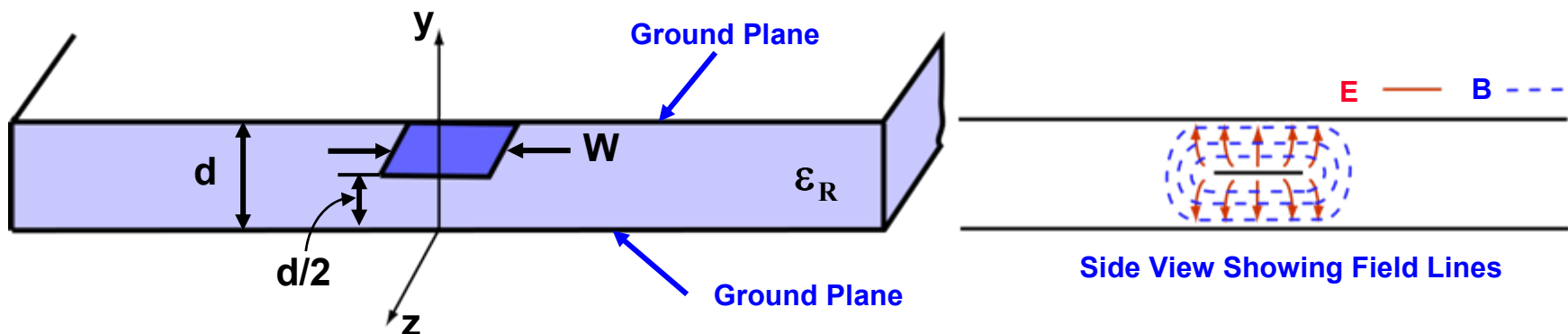

- Stripline is a planar form of transmission line
- It is often used for photolithographic fabrication and in microwave integrated circuitry (MIC)
- Normally, it is fabricated by etching the center conductor on a grounded dielectric and then covering it with an equal thickness of dielectric and another ground plane.
- In normal operation it support TEM mode propagation.



Microstrip Transmission Line

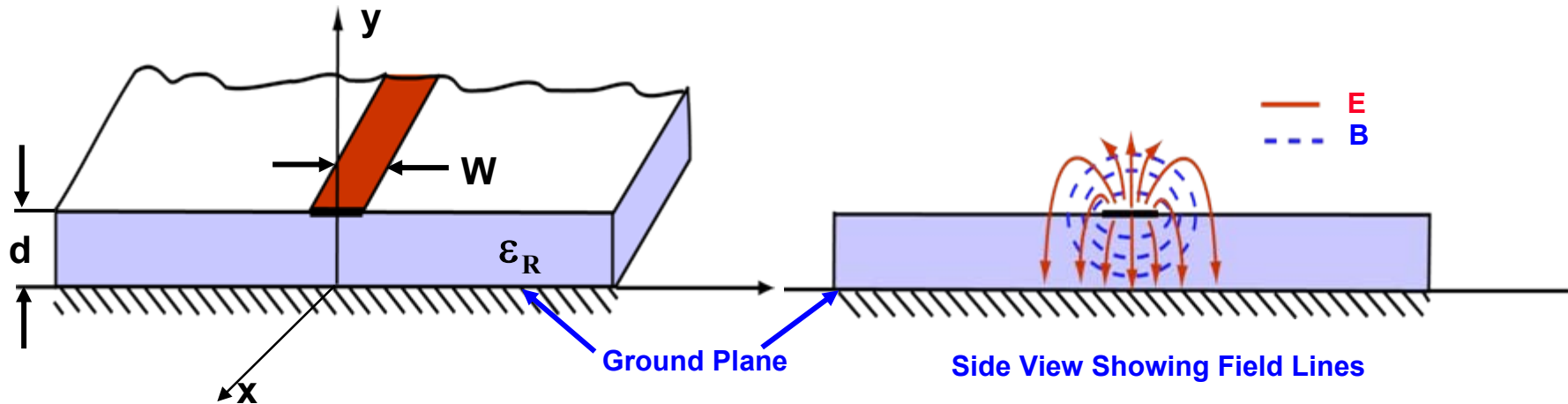

- **Microstrip in a form of planar transmission line**
 - Can be fabricated using photolithographic processes
 - Integration with active and passive microwave devices is straightforward
 - A conductor, width W , is printed on a dielectric substrate, of thickness, d
 - Substrate is grounded
 - Mode of transmission is a hybrid TM-TE wave
 - Since substrate thickness is very thin, $\lambda \gg d$, TEM propagation mode is a reasonable approximation to reality



Comparison of Transmission Line and Waveguide Characteristics



<u>Characteristics</u>	<u>Coax</u>	<u>Waveguide</u>	<u>Stripline</u>	<u>Microstrip</u>
Preferred Mode	TEM	TE ₁₀	TEM	Quasi-TEM
Bandwidth	High	Low	High	High
Physical Size	Large	Large	Moderate	Small
Power Capacity	Moderate	High	Low	Low
Loss	Moderate	Low	High	High
Fabrication Ease	Moderate	Moderate	Easy	Easy
Inter-component Integration	Hard	Hard	Moderate	Easy

Adapted from Pozar, Reference 5



X Band Slotted Waveguide Antenna (For Commercial Airborne Weather Radar)

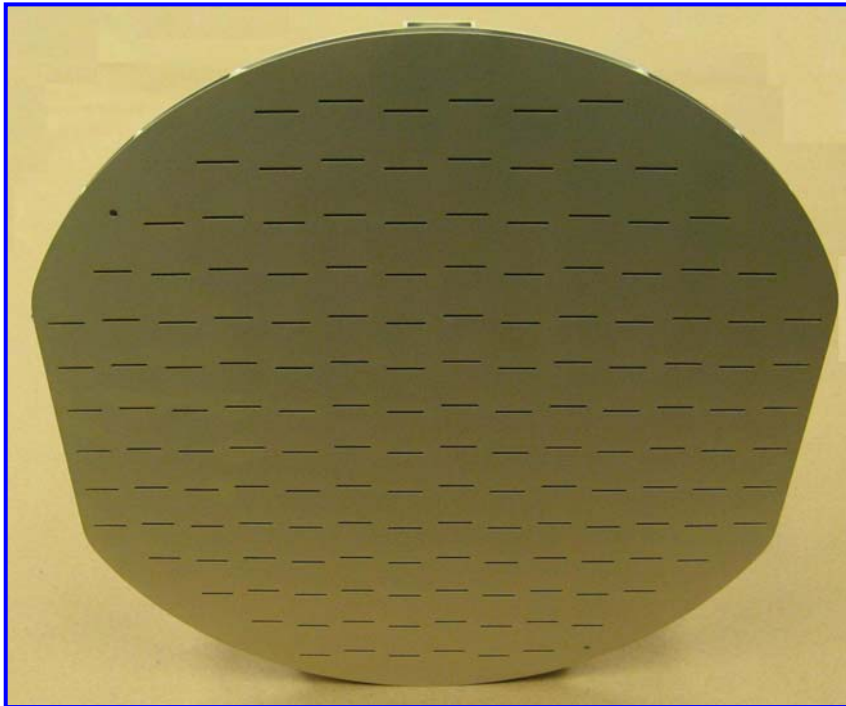

Front View



Back View

**Slotted Waveguide Antenna Produces a Pencil Beam
That is Mechanically Scanned in Azimuth and Elevation**

Courtesy of Cobham Sensor Systems.
Used with permission.

IEEE New Hampshire Section
IEEE AES Society



Other Transmitter Subsystems / Components



- **Duplexers**
- **Other Transmitter Subsystems**
 - Pulse Modulators
 - Crowbar Assem....
- **Waveguide and Transmission Lines**
- • **Microwave Integrated Circuit (MIC) technology**



Introduction to Microwave Integrated Circuit (MIC) Technology



- **Just as digital circuitry has move to technology that is smaller, lighter and more integrated in its manufacture, so has solid state microwave circuitry, denoted:**
 - **Microwave Integrated Circuitry (MIC)**
- **Hybrid microwave integrated circuitry**
 - **Common substrates: alumina, quartz, and Teflon fiber**
 - **Computer Aided Design (CAD) tools used in fabrication of mask**
 - Substrate covered with metal
 - Then etched to remove areas of unwanted metal
 - Soldering or wire bonding used to implant discrete components
- **Monolithic Microwave Integrated Circuitry (MMIC)**
 - **More recent technology than hybrid MICs**
 - **Semiconductors, such as, GaAs often used as substrate**
 - **Passive and active components grown into the substrate**
 - Multiple layers of resistive film metal and dielectric are employed to fabricate the device
 - **Complete radar T/R modules are fabricated using groups of MMIC circuits**
 - Low noise amplifiers, power amplifiers, phase shifters, receiver, etc.



Hybrid Microwave Integrated Circuit

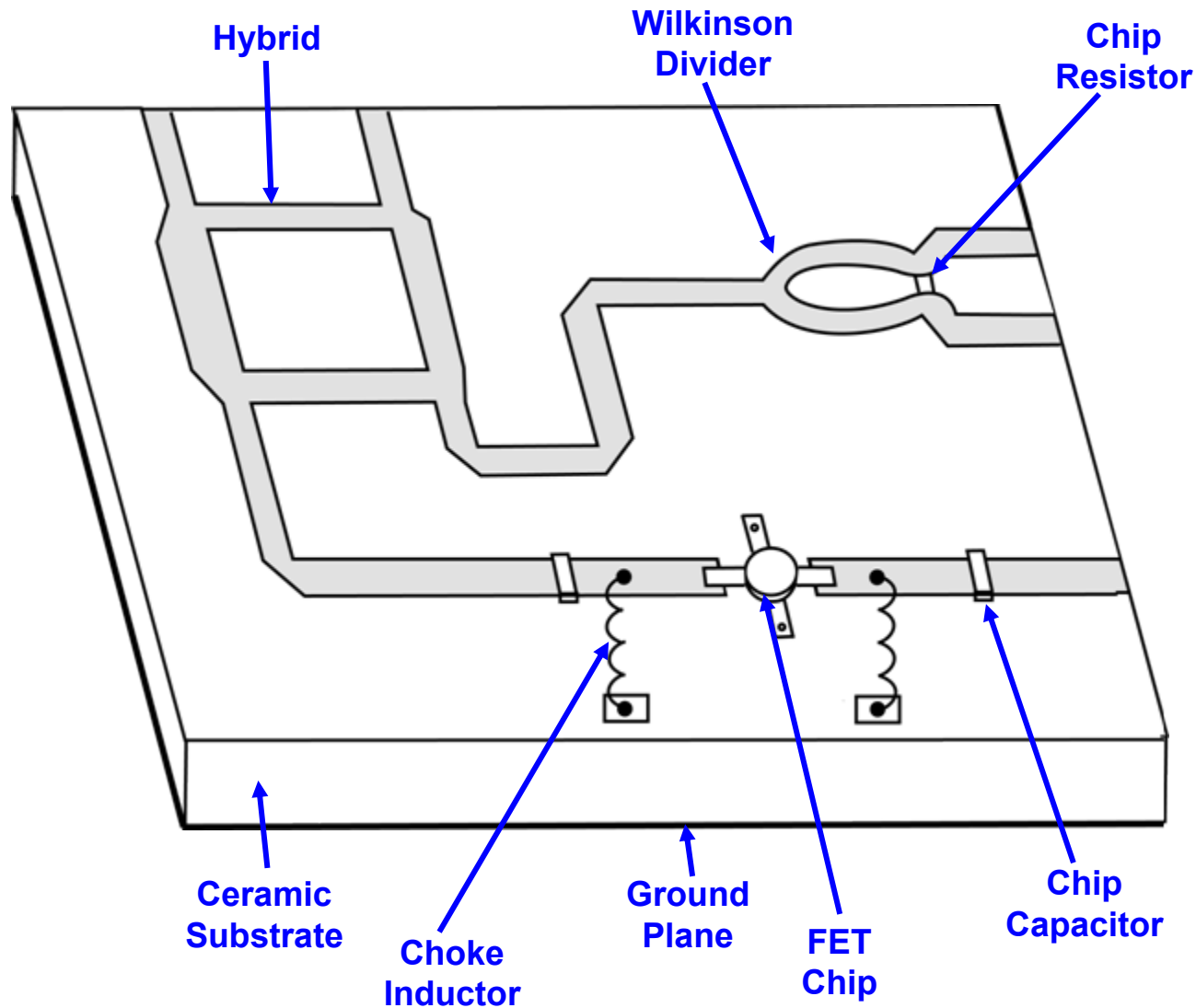

Adapted from Pozar, Reference 5



Example - Microwave Integrated Circuit



- **MIC Power Amplifier used in TPS-59 radar**

Courtesy of Lockheed Martin
Used with Permission



Example - Microwave Integrated Circuit

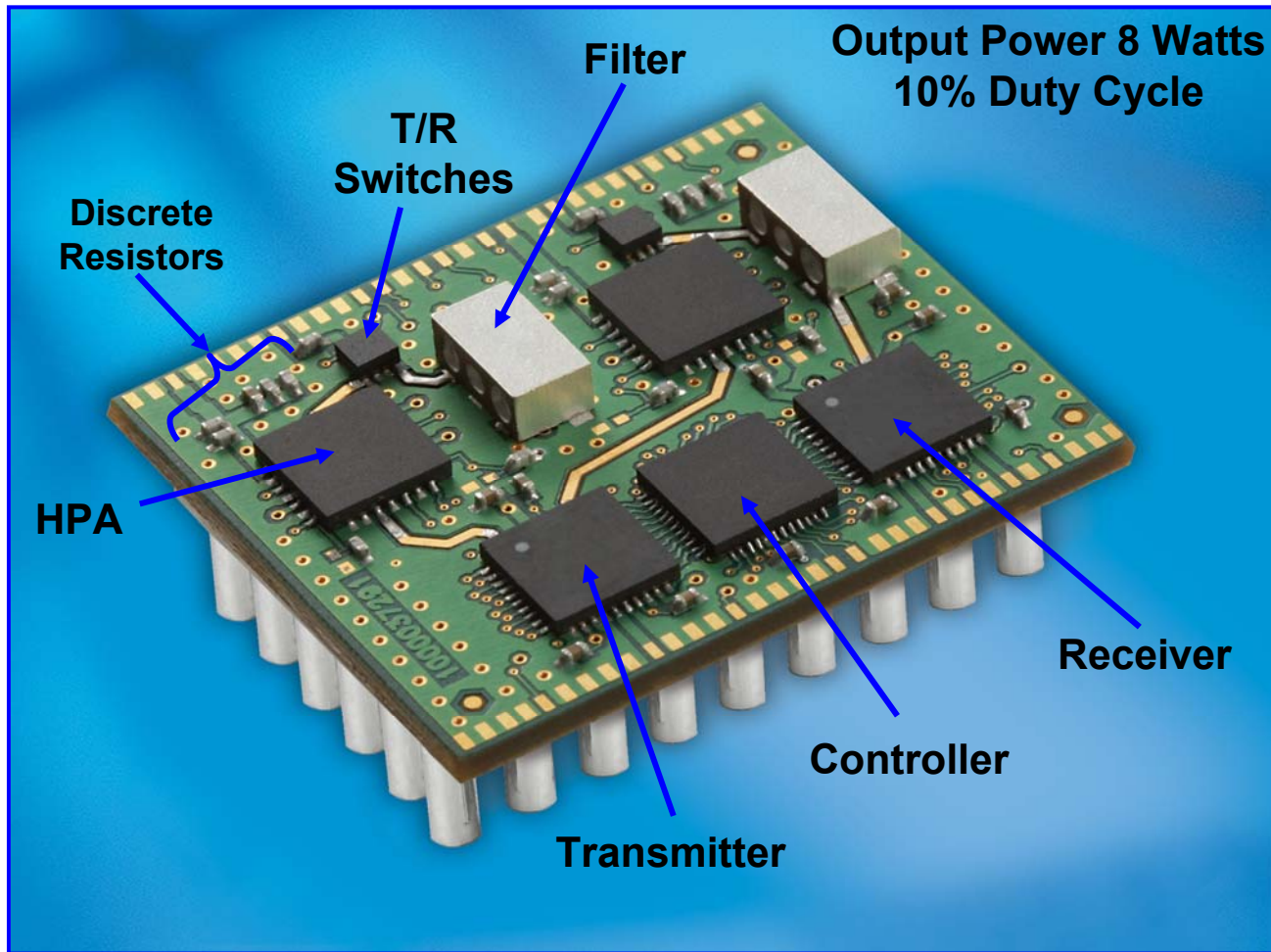

**S-Band T/R Module (2.7 – 2.9 GHz)
Multifunction Phased Array Radar
Dual Channel for Weather & Air Traffic Control**

Courtesy of MA/COM Technology Solutions
Used with permission



Layout of a Typical Monolithic Microwave Integrated Circuit (MMIC)

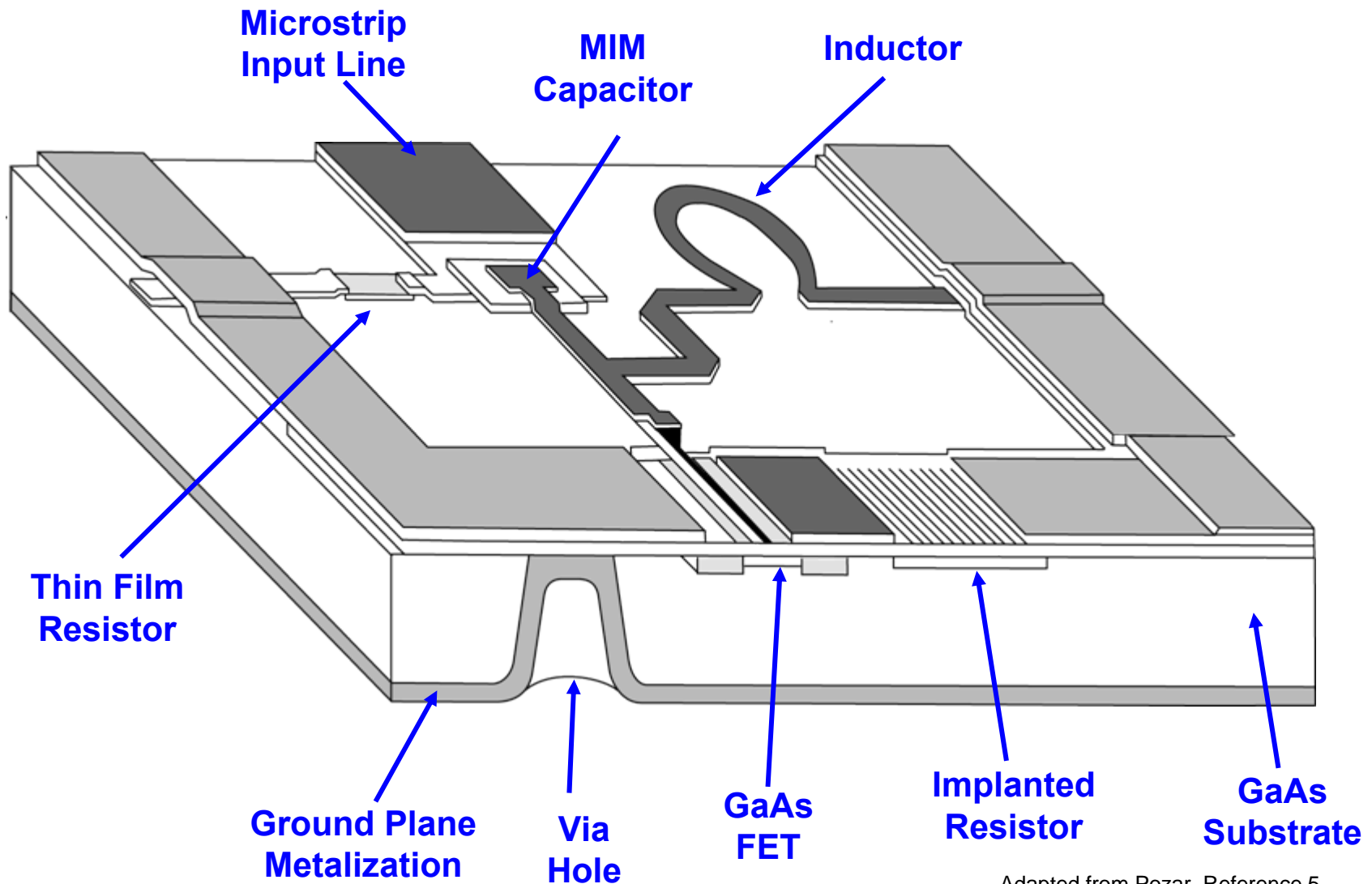

Adapted from Pozar, Reference 5

IEEE New Hampshire Section
IEEE AES Society



Monolithic Microwave Integrated Circuits (MMIC) Receiver

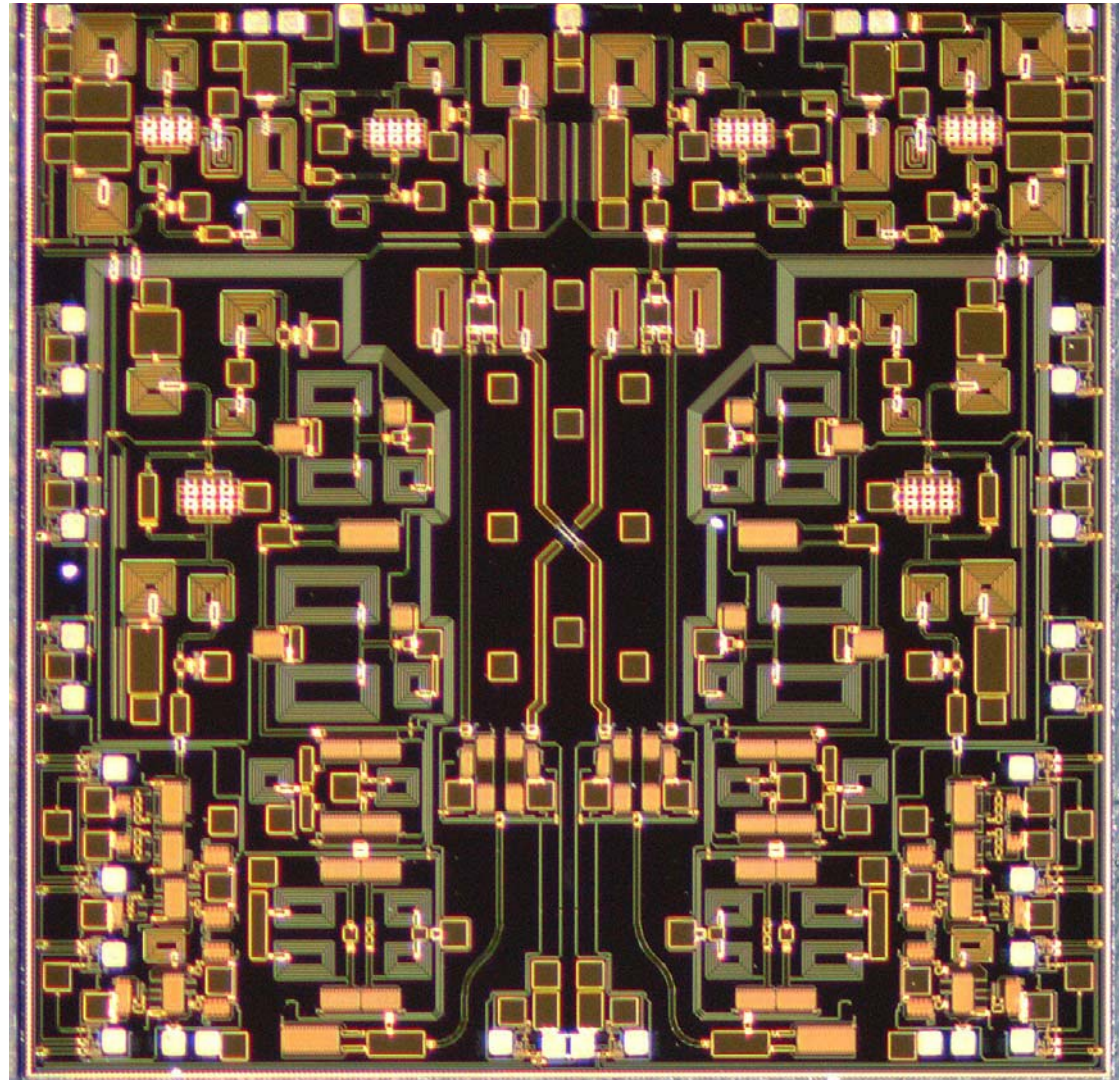
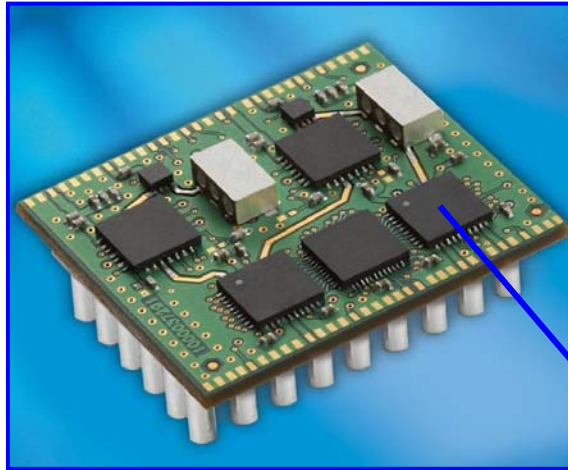

Dual Channel Receiver

- GaAs pHEMT Technology

- Integrates:

- 2 of 6-bit phase shifters
- 2 of 4-bit constant phase digital attenuators
- 2 Low Noise Amplifiers
- Switches

Size - 4 mm x 4 mm

Courtesy of MA/COM Technology Solutions
Used with permission

IEEE New Hampshire Section
IEEE AES Society



Integration into 64 Element S-Band Subarray



Individual T/R Module

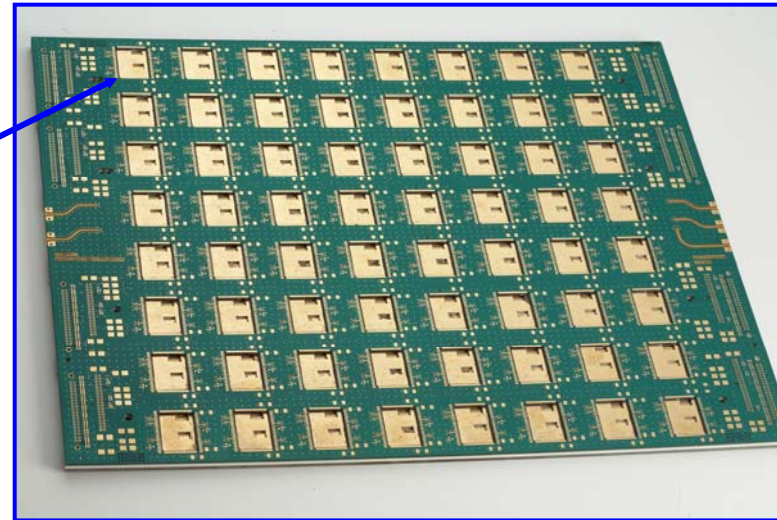
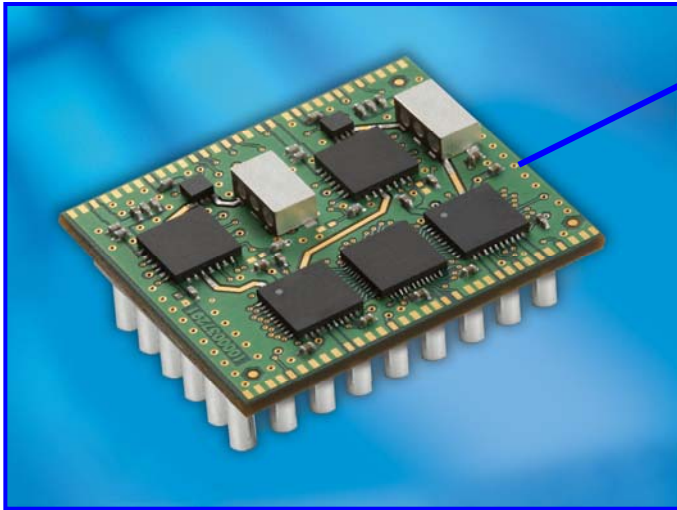

Back side of board where T/R Modules mount

**Front Side of Subarray
of 64 Patch
Radiating Elements**

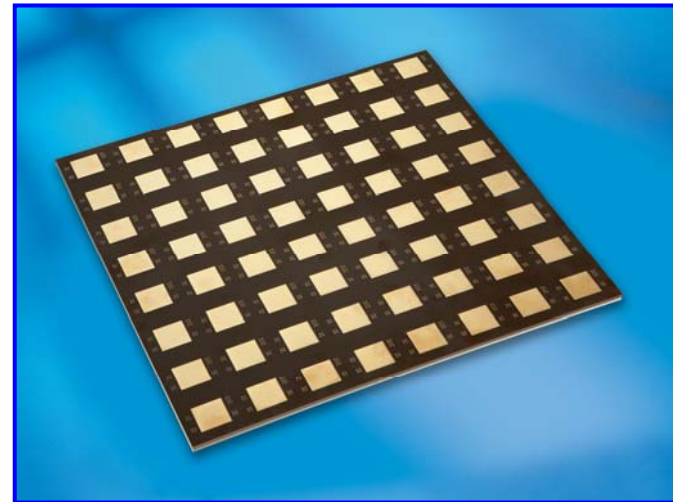

Courtesy of MA/COM Technology Solutions
Used with permission



X-Band T/R Module Using MMIC Technology

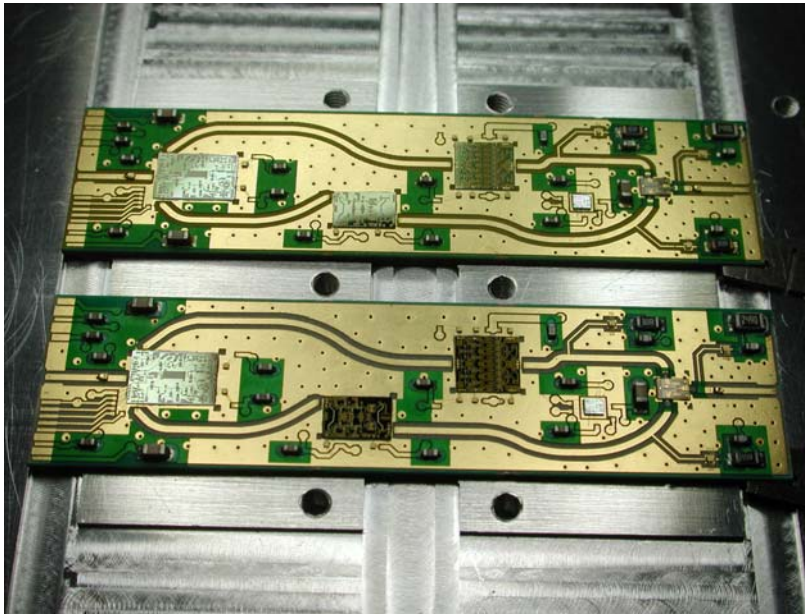
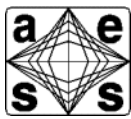

Two X-Band T/R Modules

T/R Modules
Size ~0.5 in. x ~2 in.

- Based on GaAs MSAG Technology
- Main components:
 - Phase shifter, attenuator, gain stages
 - Limiter LNA
 - High power amplifier
 - Silicon PIN Diode T/R Switch
- Built in low cost laminate technology

Courtesy of MA/COM Technology Solutions
Used with permission



Outline



- Introduction
- Transmitters
- Receivers and Waveform Generators
- Duplexers
- • Radar Transmitter- Receiver Architectures
- Summary



Radar Transmitter-Receiver Architectures



- A number of these architecture issues were discussed in the antenna lectures in the context of how they scan a volume (mechanical vs. electronic)
 - Dish antennas vs. array antennas
 - Types of array antennas
 - Active vs. Passive Scanning
 - Hybrid Antennas

Dish Antenna



TRADEX

Courtesy of MIT Lincoln Laboratory
Used with permission

Array Antenna



Patriot

Courtesy of NATO



Radar Transmitter-Receiver Architectures



- A number of these architecture issues were discussed in the antenna lectures in the context of how they scan a volume (mechanical vs. electronic)
 - Dish antennas vs. array antennas
 - Types of array antennas
 - Active vs. Passive Scanning
 - Hybrid Antennas

Passive Array Antenna

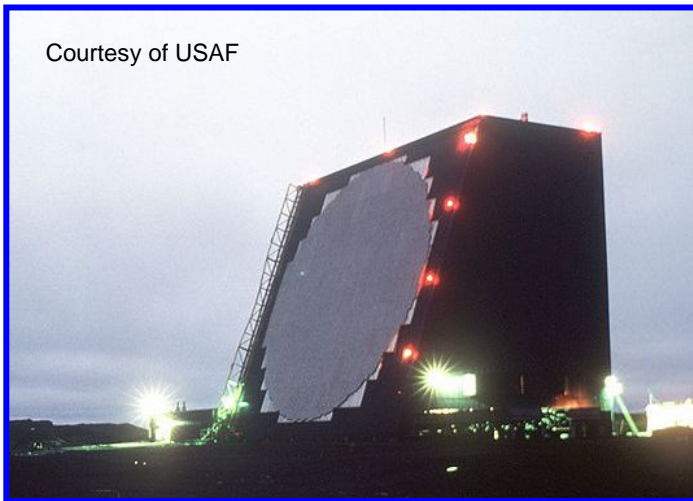

**COBRA
DANE**

Active Array Antenna

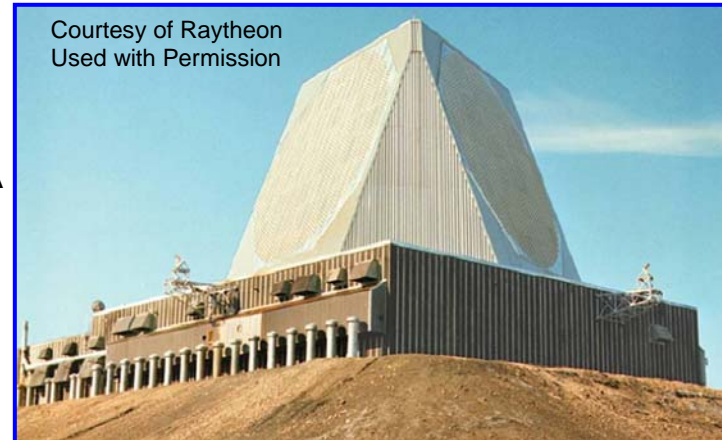

**UHF
Early
Warning
Radar**



Radar Antenna Architecture Comparison



Dish Radar

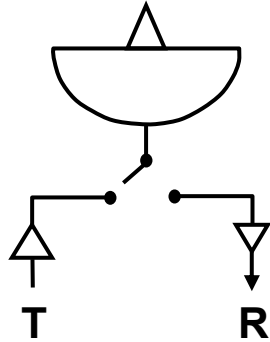

PRO

- Very low cost
- Frequency diversity

CON

- Dedicated function
- Slow scan rate
- Requires custom transmitter
- High loss

Passive Array Radar

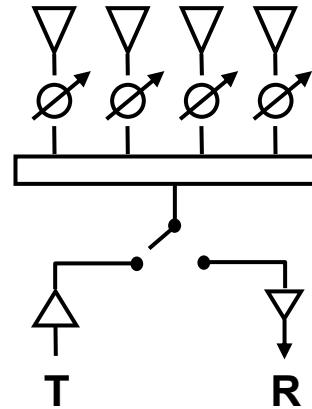

- Beam agility
- Effective radar resource management

- Higher cost
- Requires custom transmitter and high-power phase shifters
- High loss

Active Array Radar

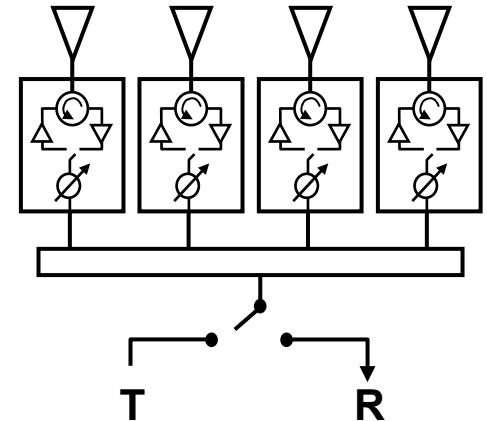

- Beam agility
- Effective radar resource management

- Low loss
- High cost
- More complex cooling

Courtesy of MIT Lincoln Laboratory
Used with Permission



Active Array Radars



Active Array

Phase Shifter
In Each T/R Module

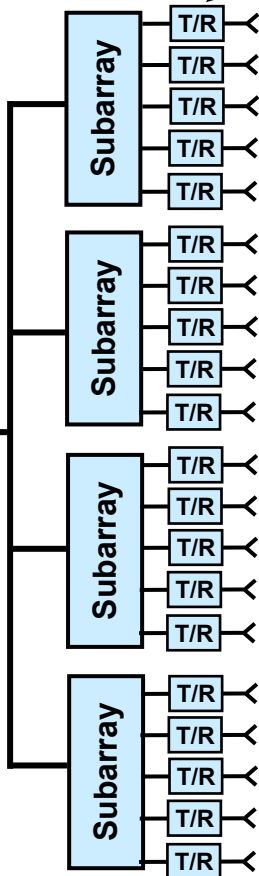

45,056
T/R Modules

SBX X-Band Phased Array Radar



Courtesy of US MDA

THAAD X-Band Phased Array Radar



Courtesy of Raytheon
Used with Permission

25,334
T/R Modules



Block Diagram of Active Radar Array Using T/R Modules

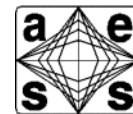

- Each T/R Module contains filtering, amplification, and amp./phase control

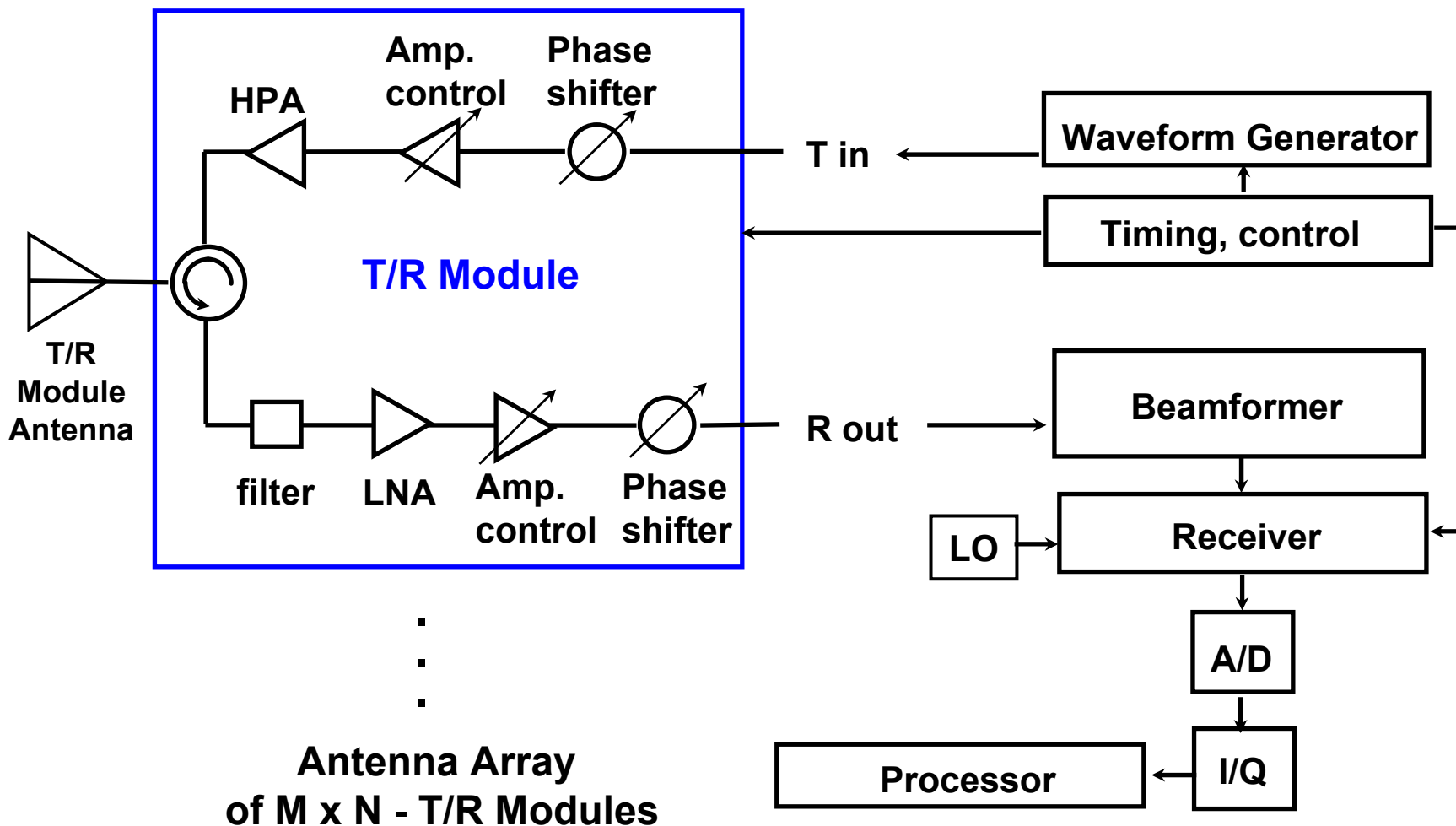



Transmit / Receive (T /R) Module Configuration

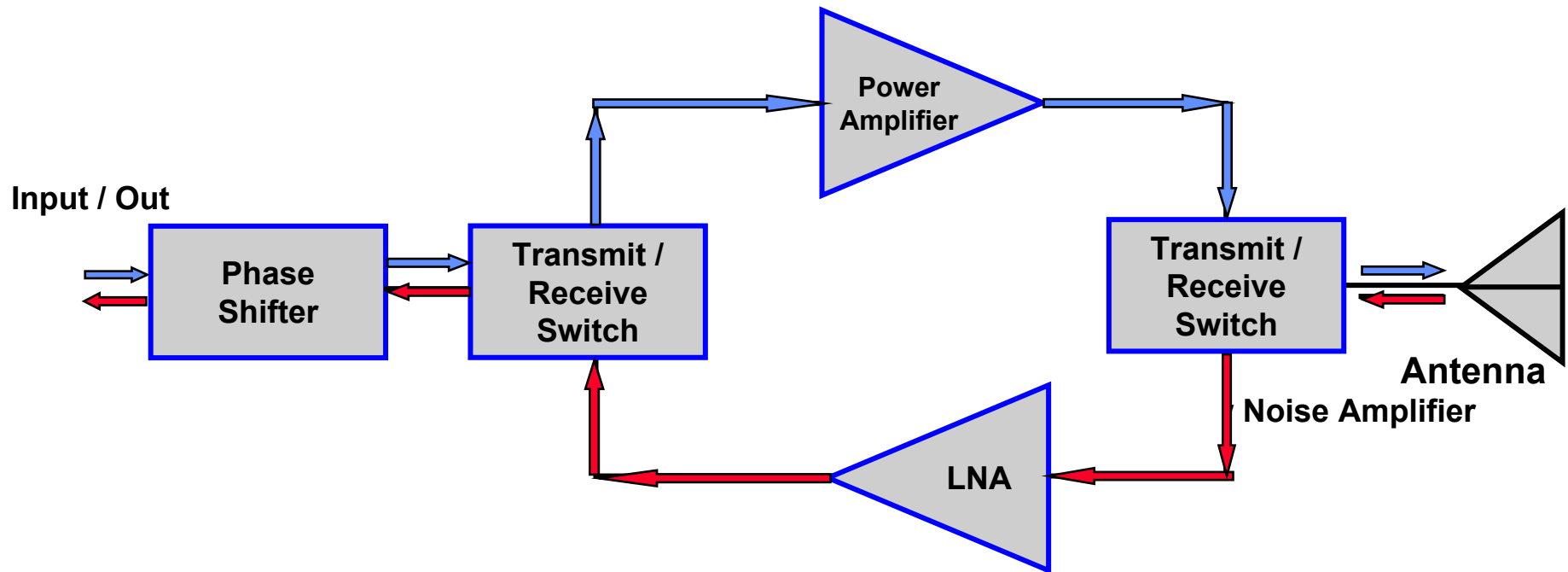



Power Amplification

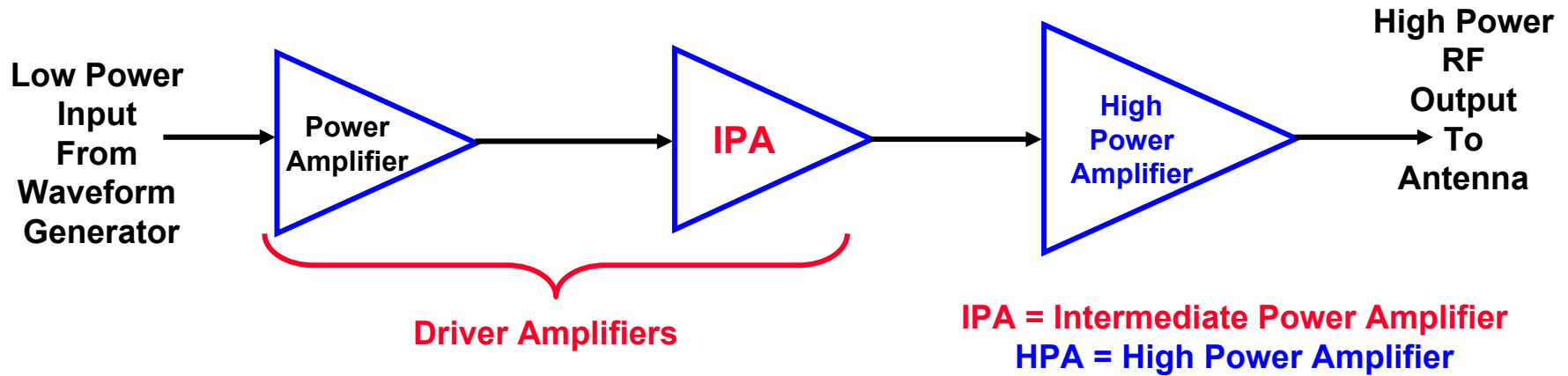
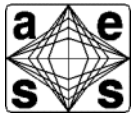

- Amplification occurs in multiple stages (Usually 2 or 3)
 - Driver amplifiers (Intermediate power amplifier)
 - High power amplifier
- Each stage may be a single amplifier or several in series and / or parallel
- Requirements for power amplifier
 - Low noise and minimal distortion to input signal
 - Minimal combiner losses, if multiple amplifiers configured in parallel



Example of Power Amplification in a T/R Module

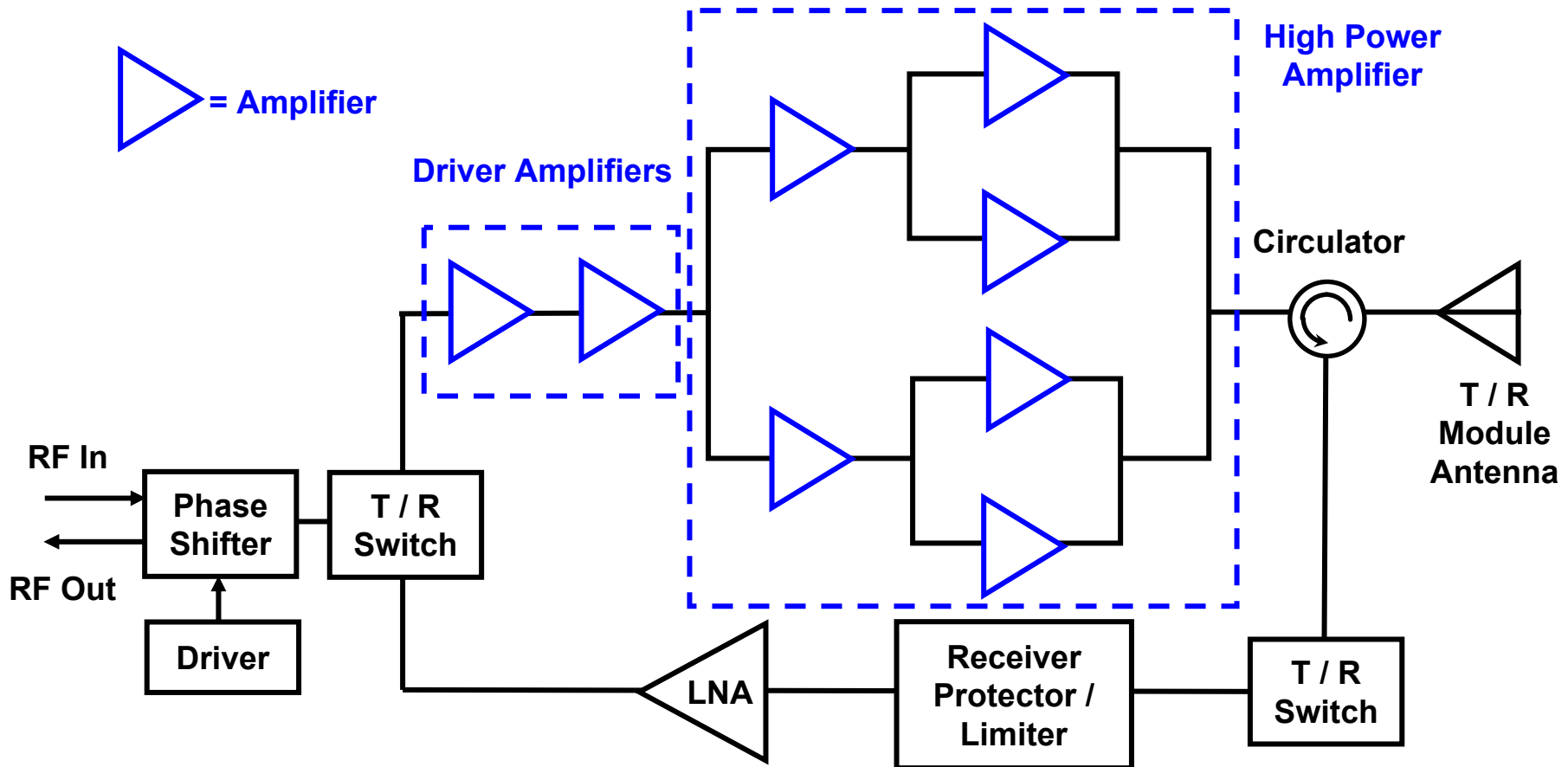
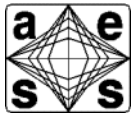

- Higher transmitted power can be obtained by combining multiple amplifiers in parallel or series
 - Combiner losses lower the ideal expected efficiency
 - More complexity



Array Radar - Digital on Receive

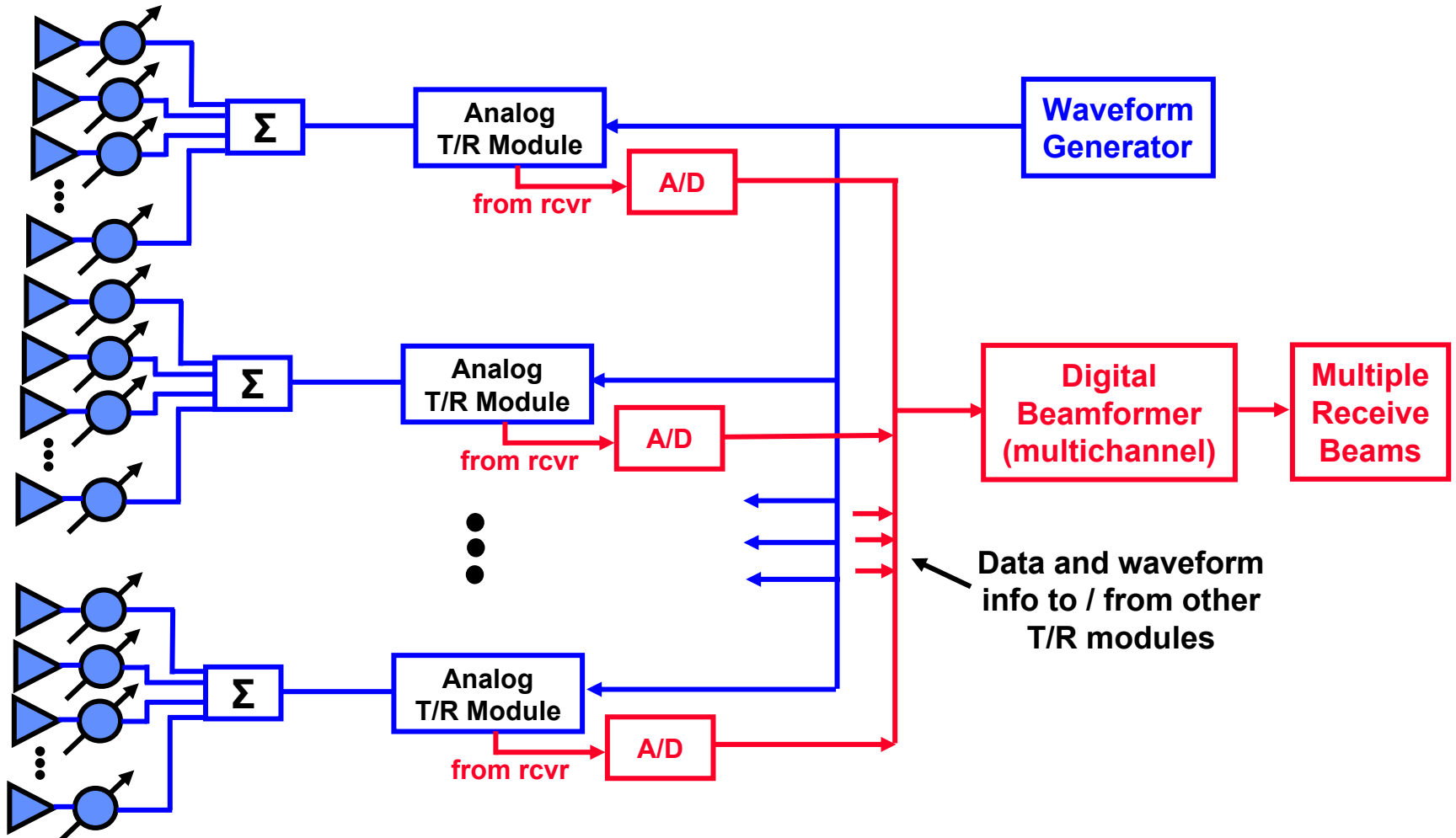

The analog T/R module receive signal is immediately digitized by an A/D converter

- The digital beamformer digitally generates multiple received beams



Array Radar - Digital on Transmit & Receive

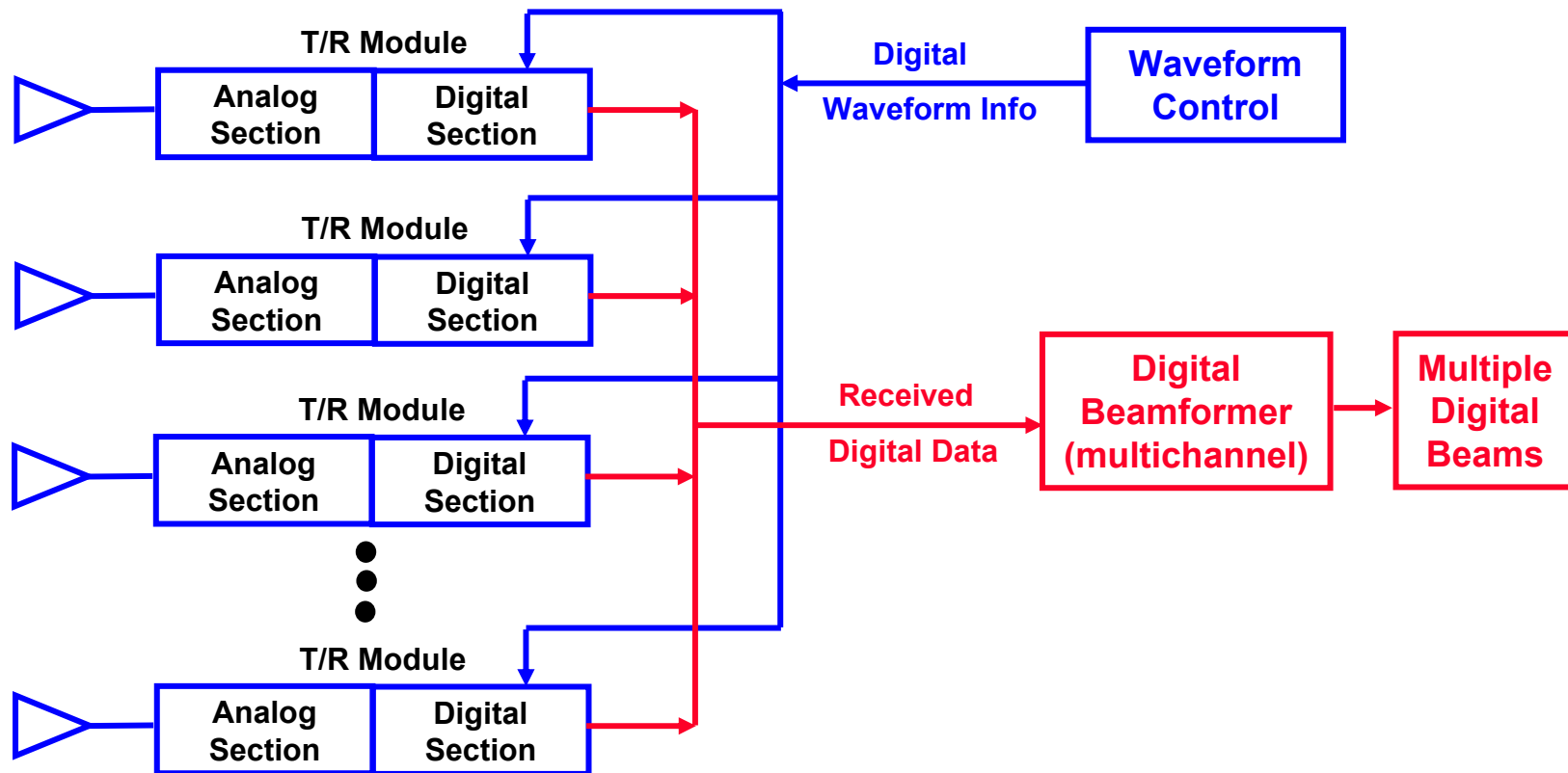

- **Digitization of the waveform generation and receiver data are performed within each T/R module**
 - **Transmit and receive options are very flexible**



Summary



- **Radar transmit function is usually divided into two parts:**
 - **Waveform generation, which creates a low power waveform signal , which is is then upconverted to RF**
 - **Power Amplifiers, then, amplify the RF signal waveform**
Tube and/ or solid state amplifiers can perform this function
- **Radar receiver performs filtering, amplification and downconversion functions and is then the signal is digitized and sent to the signal processor**
- **There are many different radar transmit/ receive architectures**
 - **Dependent on the antenna type**
 - **Centralized architecture: dish radars, passive array radars**
 - **Distributed architectures are evolving for both active array and digital array radars**



Summary (continued)



- **Klystrons, traveling wave tubes(TWT), and crossed field amplifiers(CFA) are usually used to generate high power microwave electromagnetic waves for dish radars**
- **Solid state microwave transmitters are now available**
 - **More expensive and more reliable**
 - **Used in solid state T/R modules and in lower power dish radars**
- **Duplexers are used to isolate the transmitter's high power signals from the very sensitive radar receiver**



Homework Problems

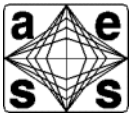

- **From Skolnik (Reference 1)**
 - **Problems 10.1 to 10.5, and 10.8**
 - **Problems 11.9, 10.12, 10.15, 10.16**
 - **Although not covered in Lecture, read Sections 11-1 to 11-3 (pp 727-745) and do problems 11.1, 11.5, 11.6, and 11.7**



References



1. Skolnik, M., *Introduction to Radar Systems*, New York, McGraw-Hill, 3rd Edition, 2001
2. Skolnik, M., Editor in Chief, *Radar Handbook*, New York, McGraw-Hill, 3rd Ed., 2008
3. Skolnik, M., Editor in Chief, *Radar Handbook*, New York, McGraw-Hill, 2nd Ed., 1990
4. Ewell, G. W., *Radar Transmitters*, New York, McGraw-Hill, 1981
5. Pozar, D. M., *Microwave Engineering*, New Jersey, Wiley, 3rd Ed, 2005



Acknowledgements



- **Dr Jeffrey S. Herd**
- **Dr Douglas Carlson, M/A COM Technology Solutions**